

# **Report of the Scientific Committee**

**Panama City, Panama, 11-23 June 2012**

**Annex H: Other Southern Hemisphere Whale Stocks (SH)  
Sub-Committee**

**International Whaling Commission, Panama City, 2012**



# Annex H

## Other Southern Hemisphere Whale Stocks (SH) Sub-Committee

### 1. INTRODUCTORY ITEMS

#### 1.1 Opening remarks

Palka welcomed the participants and then informed them that Jooke Robbins, convener of the sub-committee, was not going to be able to attend.

#### 1.2 Election of Chair

Palka and Zerbini were elected co-chairs.

#### 1.3 Appointment of rapporteurs

Bannister, Double and Zerbini acted as rapporteurs.

#### 1.4 Adoption of the Agenda

The adopted agenda is given in Appendix 1.

#### 1.5 Review of documents

The following documents were available for to the meeting: SC/64/SH1-30, SC/64/O15-O17, Acevedo *et al.*, 2011; Pastene *et al.*, 2011; Galletti Vernazzani *et al.*, in press; Sremba *et al.*, 2012; Constantine *et al.*, 2012; Branch 2011; Paton *et al.*, 2011; Salgado-Kent *et al.*, 2012).

### 2. ASSESSMENT OF SOUTHERN HEMISPHERE HUMPBACK WHALES

The IWC Scientific Committee currently recognizes seven humpback whale breeding stocks (BS) in the Southern Hemisphere (labeled A to G; IWC, 1998), which are connected to feeding grounds in the Antarctic. An additional population that does not migrate to high latitudes is found in the Arabian Sea. Assessments of BSA (western South Atlantic), BSD (eastern Indian Ocean) and BSG (eastern South Pacific) were completed in 2006 (IWC, 2007), although it was concluded that BSD might need to be re-assessed with BSE and BSF in light of mixing on the feeding grounds. An assessment for BSC (western Indian Ocean) was completed in 2009 (IWC, 2010) and for BSB in 2011 (IWC, 2012).

#### 2.1 Assessment of breeding stocks D, E and F

At last year's meeting, the sub-committee initiated the re-assessment of BSD, and the assessment of BSE and BSF. These stocks correspond, respectively, to humpback whales wintering off Western Australia (stock D), Eastern Australia (sub-stock E1) and the western Pacific Islands in Oceania including New Caledonia (sub-stock E2), Tonga (sub-stock E3) and French Polynesia (sub-stock F2) (Fig 1).

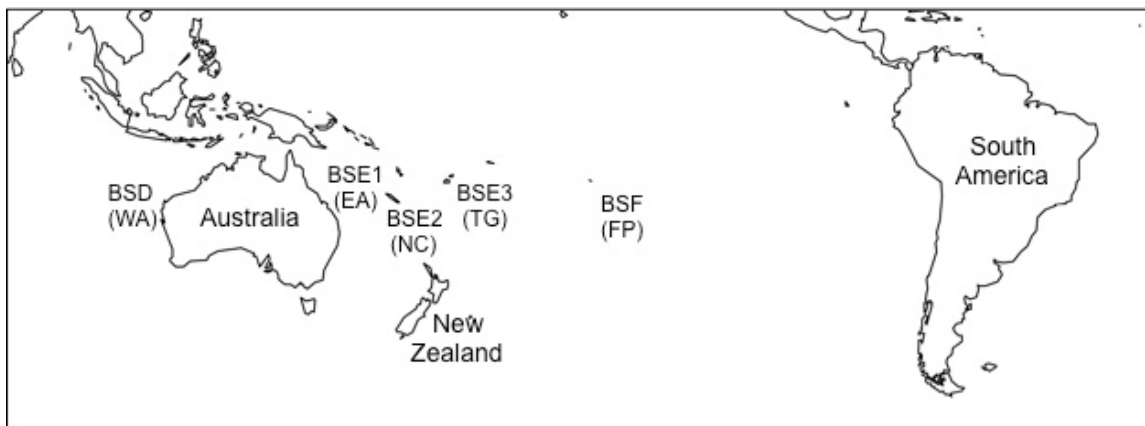

Fig 1. Distribution of Southern Hemisphere humpback whales breeding stocks grounds for BSD, BSE1, BSE2, BSE3 and BSF2 (WA = Western Australia, EA = Eastern Australia, NC = New Caledonia, TG = Tonga and FP = French Polynesia).

### 2.1.1 Abundance, trends and catches

SC/64/SH6 presents abundance and trend estimates from the New Caledonia humpback whale breeding ground (IWC sub-stock E2) using fluke photo identification data collected over 16 years (1996-2011). Estimates of abundance have been calculated using both closed (CAPTURE 3-4 year intervals) and open models (POPAN and CJS). The POPAN open model abundance estimate from 2008 was 562 whales (CV=0.19, CI 351-772). An earlier abundance estimate using photo-identification for this population (spanning 1996-2005) indicated a very small population (N=344, CI 208-480, CV=0.72). Beginning in 2006 through our current estimate to 2011 all population models examined show a trend of increasing abundance with a large 'pulse' after 2008. This pattern of abundance is similar over all survey areas. Whether these whales represent part of the New Caledonia sub-stock or permanent or temporary immigration from different regions is currently unclear. The authors hypothesized that this anomalous increase could be an overspill of the East Australia population, which is currently increasing at a high growth rate. Further analysis in future years will help to track the origin of these whales and to decipher if this is indeed an anomalous 'pulse' of visitors or the beginning of a trend in population growth.

In discussion, it was noted that a phenomenon similar to that observed in New Caledonia in the late 2000s had also been recorded off Eastern Australia in the late 1980s (Chaloupka *et al.*, 1999). A possible movement of Eastern Australia whales to New Caledonia was consistent with an observed decrease in the rate of population growth of whales migrating off the Australian coast (Noad *et al.* 2011), although the authors of this study attributed the decline to an anomalous survey year in 2007. In response to a question, authors clarified that data are not yet sufficient to assess whether a 'pulse' of E1 animals could be detected in the data by an increase in numbers of transient whales. It was also noted that a comparison of photo-identification catalogues of East Australia and New Caledonia might be useful to assess whether the 'pulse' observed in the latter would really correspond to East Australian whales. However it was cautioned that since the East Australian population is estimated to be over 14,000 animals (Noad *et al.* 2011), recapture probabilities of individuals are low, so a very large population sample would be required to discriminate different levels of interchange with New Caledonia at different time periods with any precision. In response to a question, authors indicated that biopsy samples are available so they would be able to examine whether the sex ratio has changed during the pulse.

Concerning potential pulses of animals coming into New Caledonia, it was noted levels of Fst differentiation between E1 and E2 (0.01, Olavarria *et al.* 2006) were the lowest among any pair of populations in Oceania and are similar in magnitude to those seen within the west and east African sub-stocks BSB and BSC (Rosenbaum *et al.* 2009).

It was noted that an estimate of an apparent survival probability ( $\Phi$ ) of 0.85 with the Pradel model is inconsistent with a growing population and was therefore indicative that whales could be moving outside the study area since this metric represents a combination of mortality and emigration. New Caledonia appears to be subject to distributional shifts (e.g. due to an expansion of Eastern Australian whales or responses to environmental variation). Its current level of demographic independence from East Australia is therefore uncertain.

New estimates of abundance and trends for Western Australian humpback whales (Salgado-Kent *et al.*, 2012) were reviewed. Five years (2000, 2001, 2006, 2007 and 2008) of aerial surveys carried out over an eight-year period at North West Cape (NWC; Western Australia) using line transect methodology potentially allow trends in whale numbers to be investigated, and provide a base for comparison with estimates made approximately 400 km south at Shark Bay (Western Australia). A total of 3,127 whale detections were made during 74 surveys of the 7,043km<sup>2</sup> study area west of NWC. Pod abundance for each flight was computed using a Horvitz- Thompson like estimator and converted to an absolute measure of abundance after corrections were made for estimated mean cluster size, unsurveyed time, swimming speed and animal availability. Resulting estimates from the migration model of best fit with the most credible assumptions were 7,276 (CI = 4,993–10,167) for 2000, 12,280 (CI = 6,830–49,434) for 2001, 18,692 (CI = 12,980–24,477) for 2006, 20,044 (CI = 13,815–31,646) for 2007, and 26,100 (CI = 20,152–33,272) for 2008. Based on these data, the trend model with the greatest R<sup>2</sup> was exponential with an annual increase rate of 13% (CI = 5.6%–18.1%).

In discussion, it was pointed out that the surveys around NWC were conducted during both the northward and southern migration periods, raising difficulties in interpreting the resultant migration count-based estimates. Furthermore, Salgado-Kent *et al.* (2012) report that during the southern migration, whales are frequently observed milling, perhaps utilizing the Exmouth Gulf, just east of NWC as a resting area. Acknowledging these difficulties, the authors attempt to resolve these two significant issues by adopting three different strategies for modelling the migration counts. It is not clear that any of these three methods adequately address the issue – mixing of the migration streams and milling individuals when it is unclear what portion of the population is being surveyed, as discussed in SC/64/SH28. Survey location and associated issues aside, there were some questions raised about the analyses. Perhaps principal among these was the decision to right-truncate the perpendicular distance data at a distance somewhat beyond the inter-transect spacing (truncating at 13 km with a transect spacing of 10 km). Potentially this could introduce bias due to double-counting, but also the pooled detection functions showed considerable lack-of-fit at the origin, possibly owing to the long tail in the distribution of perpendicular distances. It was noted that more extreme truncation would preclude the use of some flights (towards the beginning and end of the survey periods) with few sightings. It was commented that alternative analysis options (such as pooling the detection

function across flights) may be a more appropriate way of including these data, permitting truncation at smaller distances, and potentially giving more reliable estimates of effective strip half width, *eshw*. The paper describes a method of incorporating availability bias based on Laake *et al.*'s (1997) approach, but seemingly implemented differently. Some questions of clarification were raised regarding the apparent dependence of availability on perpendicular distance, leading to very low conditional probabilities of detection, but as the authors were not present it was not possible to pursue these.

In discussion, it was noted that though the location of the surveys presented problems, which are difficult to address analytically, the sub-committee would welcome further analyses that address some of the other queries raised so that it can further consider the use of these abundance estimates in the assessment at next year's meeting. The sub-committee **recommended** that contacts are initiated with the authors intersessionally and that, if necessary, they are invited to SC/65 for further discussion of their work.

### 2.1.2 Distribution, movement and population structure

Four documents were available for discussion of this agenda item, SC/64/SH5, SC/64/SH15, SC/64/SH22, and Pastene *et al.* (2011). These documents were reviewed by the Working Group on Stock Definition and their conclusions are reported in Annex I, Item 3.1.1.

### 2.1.3 Assessment models

SC/64/SH29 provided initial results of population model fits to the Southern Hemisphere humpback whale breeding grounds D (West Australia; BSD), E1 (East Australia; BSE1) and Oceania (BSE2, BSE3, and BSF2). The purpose of the document was to present preliminary results to facilitate further discussion and model runs during the meeting. The initial results indicated that BSD is near to its pristine abundance, BSE1 is at an intermediate level, and Oceania is still heavily depleted. There were inconsistencies noted between the model and the various relative abundance indices for stock D, and the authors suggested further discussion of the matter during the meeting.

In discussion, the sub-committee noted that previous assessments (Johnston and Butterworth, 2006) considered mixing of BSD and BSE1 in the feeding grounds not implemented in SC/64/SH29 and that different catch allocation in a mixing model could potentially explain the inconsistencies seen for BSD. A re-examination of results from a model accounting for feeding grounds mixing resulted in similar outcomes, suggesting other factors may be responsible for such inconsistencies. The sub-committee **agreed** that the inconsistencies in the model predicted population trajectories and the abundance data for BSD required further examination. There was insufficient time to discuss this at the meeting and the sub-committee **agreed** this should be examined at next year's meeting.

It was noted that the model-predicted abundance estimate for Oceania in 2004 in SC/64/SH29 is incompatible with the POPAN capture-recapture abundance estimate computed with software MARK from Constantine *et al.* (2012) even though the same input data was used in the two papers. It was suggested that this lack of consistency might occur because the population dynamics model assumes a Poisson likelihood while the POPAN model in MARK uses a multinomial likelihood. It was **agreed** that implementing the latter in the Bayesian population dynamics model would be attempted for next year's meeting.

The model structure presented in SC/64/SH29 did not take into account the documented connectivity between breeding grounds in Western (D) and Eastern Australia (E1) and Oceania (E2+E3+F2) and between these breeding and feeding grounds, although this information is available. A new model structure was therefore developed to account for movement between these areas (Fig. 2). This movement model pooled all breeding grounds in Oceania into one single population, which is not entirely consistent with existing demographic and genetic data (e.g. Olavarria *et al.*, 2006, 2007). The sub-committee recognizes that while existing evidence indicates Oceania has a complex structure, a model with a simpler structure for this region can be used for initial exploration and more elaborate model configurations can be proposed once results are examined. The model presented in Fig. 2 can be implemented in a similar fashion to the movement models used in the assessment of breeding sub-stocks C1 and C3 (IWC, 2010) and is presented in more detail in Appendix 2. The migrant model will be used as the reference case model in the BSD, E, and F assessment.

The sub-committee also **agreed** that the exploration of a two stock model for Eastern Australia and Oceania would be valuable to inform the assessment. There was insufficient time to discuss this model in detail but a rationale for its implementation is presented in Appendix 3.

The sub-committee **agreed** that the feeding areas associated with each of the three breeding stocks for catch allocation should be defined according to Hypothesis 1 of IWC (2010). Thus, catches will be allocated in the following manner:

Catches associated with Breeding Stock D feeding area:

- 50% of catches taken between 60°E and 80°E (marginal C/D region)
- 100% of catches taken between 80°E and 110°E (core D region)

- 50% of catches taken between 110°E and 130°E (marginal D/E region)

Catches associated with Breeding Stock E1 feeding area:

- 50% of catches taken between 110°E and 130°E (marginal D/E region)
- 100% of catches taken between 130°E and 160°E (core E region)
- 50% of catches taken between 160°E and 180°E (marginal E/F region)

Catches associated with Oceania Breeding Stocks:

- 50% of catches taken between 160°E and 180°W (marginal E/F region)
- 100% of catches taken between 180°W and 120°W (core F region)
- 50% of catches taken between 120°E and 100°W (marginal F/G region)

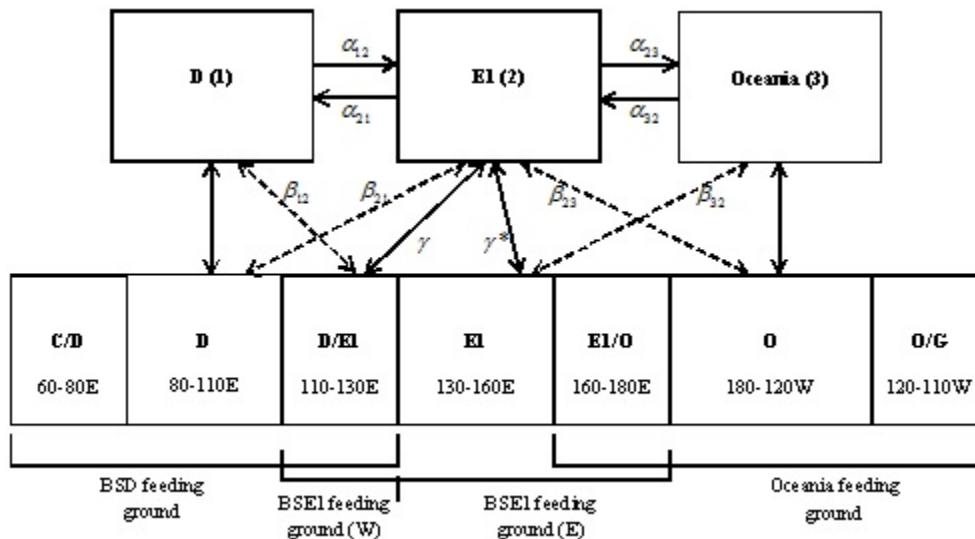

Fig. 2. Proposed model structure for breeding stocks D, E1 and Oceania. Arrows indicate possible interchange between stocks. These interchange rates will be estimated in the model, informed by data given in Table 1. Solid lines indicate movement of a breeding population to its own feeding ground, while dashed arrows indicate whales moving to a neighbouring feeding ground. Note that in order to avoid three breeding stocks mixing in the E1 feeding ground, an artificial boundary for catch allocation has been imposed. No catches taken east of this boundary will be allocated to BSD, while no catches taken west of the boundary will be allocated to Oceania. 130°E was chosen based on the longitudinal range of documented connections between BSD, Oceania and the Antarctic (J. Jackson, *pers. comm.*).

In discussion of the available data for the assessment, the sub-committee was informed that current estimates of interchange between Eastern Australia and Oceania and mark-recapture population estimates derived from microsatellite genotypes and photo-identification data are not inclusive of all known existing data sets. In particular the large photo-identification catalogue (6,500+ IDs from 1984-2011) held by Pacific Whale Foundation (PWF) has not been included in any interchange analysis conducted to date. PWF hold data collected on the Great Barrier Reef and in southern migratory waters of New South Wales that may be of value for future assessments. It was also noted that the photo-identification catalogues from Western and Eastern Australia and Oceania have not yet been matched to the Antarctic humpback whale catalogue. The sub-committee **encouraged** reconciliation of these catalogues to inform future assessments of Southern Hemisphere humpback whales.

The sub-committee discussed the suitability of using Discovery mark data to better inform the assessment. Such data was collected during whaling periods and precedes the more recent photo-identification and genotype datasets. The sub-committee **agreed** that these data, which contain information on movements between breeding grounds, between feeding grounds, and between breeding and feeding grounds, could be informative and should be explored in the context of the assessments.

The sub-committee also **agreed** that genetic data presented in Pastene *et al.* (2011) could be used to inform relative proportions of mixing in the feeding grounds. It was noted that these data are missing samples from Eastern Australia (E1). The sub-committee **recommended** that Pastene request the E1 data through the Data Availability Group, conduct a new analysis incorporating all available data and provide the results to the intersessional working group by the end of 2012 so that it can be incorporated into the assessment.

The sub-committee noted that abundance estimates in the feeding grounds from both IDCR-SOWER (Branch, 2011) and JARPA (Matsuoka *et al.*, 2011) do not correspond exactly to the catch allocation boundaries in Hypothesis 1 (IWC, 2011). It was **agreed** that the use of these data as sensitivity in the population assessment models will be pro-rated assuming uniform density by longitude within current boundaries. The sub-committee was informed that the JARPA program will continue and that data generated by this program will be available for future assessment of humpback whales.

After reviewing the data available, the sub-committee **agreed** on input data for the population dynamics model (Table 1). These data were classified as acceptable for use in a reference case, for sensitivity analyses or for consistency check. It was also **agreed** that datasets that are not yet available should be provided by 31 December 2012, after which time no more new data will be used for this assessment (see item 5.1).

Table 1  
Input data to be used in the assessment of breeding stocks D, E and F

BREEDING GROUND DATA				
ABUNDANCE AND TREND DATA				
Type of data	Reference	Status	Implementation	Stock/Region
Absolute abundance	Hedley <i>et al.</i> (2011)	Available	Reference case	D
Relative abundance	Hedley <i>et al.</i> (2011)	Available	Reference case	D
Relative abundance	Bannister & Hedley (2001)	Available	Sensitivity	D
Relative abundance	Chittleborough (1965)	Available	Consistency check	D
Absolute abundance	Noad <i>et al.</i> (2011)	Available	Reference case	E1
Absolute abundance	Paton <i>et al.</i> (2011)	Available	Consistency check	E1
Relative abundance	Noad <i>et al.</i> (2011)	Available	Reference case	E1
Relative abundance	Forrestell <i>et al.</i> (2011)	To be provided	TBD	E1
Mark-recapture	Paton <i>et al.</i> (2011)	To be provided	TBD	E1
Mark-recapture	Forrestell <i>et al.</i> (2011)	To be provided	TBD	E1
Absolute abundance	Constantine <i>et al.</i> (2012)	Available	Consistency check	Oceania
Mark-recapture	Constantine <i>et al.</i> (2012)	Available	Reference case	Oceania
DATA FOR INFORMING INTERCHANGE				
Type of data	Reference	Status	Implementation	Stock/Region
Photo-identification mark-recapture	G. Kaufman	To be provided	TBD	D and E1
Genetic mark-recapture	Anderson	Available	TBD	D and E1
Genetic mark-recapture	J. Jackson	To be provided	TBD	E1 and Oceania
FEEDING GROUND DATA				
Type of data	Reference	Status	Implementation	Stock/Region
Relative abundance	Matsuoka <i>et al.</i> (2011)	Available	Sensitivity and/ or consistency check	Feeding grounds (JARPA)
Relative abundance	Branch (2011)	Available	Sensitivity and/ or consistency check	Feeding grounds (IDCR-SOWER)
Relative proportions of breeding stocks in feeding grounds	L. Pastene	To be provided		

The sub-committee **agreed** that the assessment of breeding stocks D, E1 and Oceania would likely take longer than anticipated at last year meeting. It proposed to complete analysis of the model specified above during the intersessional period and to bring results at next year's meeting for further discussion. To ensure this work is complete the sub-committee recommended an intersessional working group convened by Muller. The terms of reference are to complete the work plan (Table 2.) and present results of the assessment models at the 2013 Annual Meeting. It anticipates that the assessment of these stocks shall be completed in 2014.

#### 2.1.4 Future work

SC/64/SH28 reported on the outcome of a workshop held in November, 2011 to discuss surveys and analyses of Breeding stock D humpback whales at two locations off Western Australia - North West Cape and Shark Bay. The workshop reviewed existing analyses from the two sites and noted that results from neither site had produced conclusive estimates of absolute abundance of this population. The workshop had also discussed possible survey methods for estimating absolute abundance of this population in future (including aerial line transect surveys, cue-counting and land-based surveys) and the most appropriate location(s) for such surveys. It identified two potential sites for future surveys - Yardie Creek, on the west of North West Cape, and southern Dirk Hartog Island. Southern Dirk Hartog Island has the advantage that it should be easier to distinguish between the northward and southern migration but there was some suggestion that whales could pass closer to the shore at Yardie Creek. As a result of logistical uncertainties and some further work required to ascertain the most appropriate nature of an aerial survey (cue-count, double-platform or racetrack) for this population, SC/64/SH28

presents plans for a pilot survey at the two proposed locations. Prior to such a survey, some simulation work would be needed to determine the operational protocols for the racetrack method, which has previously not been extensively used on species other than harbour porpoise. The pilot survey would then trial both cue-counting and racetrack aerial survey methods, in conjunction with land-based work at both locations, to determine the most appropriate survey method for a full-scale absolute abundance survey in the near future.

**Table 2**  
Work plan for the assessment of breeding stock D, E1 and Oceania

1.	Additional data required (Deadline December 2012)
a.	Photo-ID mark-recapture data for D-E1-Oceania (Kaufman)
b.	Genetic mark-recapture data for D-E1 (Anderson)
c.	Genetic mark-recapture data for E1-Oceania (Jackson)
d.	Feeding ground mixing proportions (Pastene)
e.	Analysis of tag data (Palka)
2.	Modelling work (Müller/Butterworth and Jackson)
a.	Compatibility with MARK absolute abundance estimates with Bayesian population estimates: Implement a multinomial approach to be used in the Bayesian models instead of the Poisson approach (Butterworth and Müller)
b.	Bayesian assessment models (Müller / Johnston / Butterworth)
c.	Population modelling of East Australia and Oceania (Jackson)

The sub-committee discussed the circle-back method. This method was originally developed to survey harbour porpoise (Hiby 1999; Hiby and Lovell 1998) and would require modification to suit the grouping characteristics and dive behaviour of whales in this region. This can be explored through simulation. If the target species is highly clustered, then it may be difficult to determine duplicate sightings. However, this could be mitigated by using this approach only at times of lower density. It was noted that circle back is difficult to implement and requires many duplicates – over fifty duplicates are required for porpoises but fewer may be required for humpback whales. Cue counting was originally developed for humpback whales off Greenland but again to be successful it needs to be carefully implemented.

In regards to the potential of acoustic methods to estimate relative abundance, it was noted that interpretation of such data is not yet clear and further analytical development is still required. Similarly, a mark-recapture approach through matching close-kin could be possible but still requires further theoretical and logistical assessment before it is considered a viable option. The sub-committee also reiterated the value of obtaining absolute abundance estimates for estimating population trend and efforts should favour techniques that can deliver absolute rather than relative abundance.

The sub-committee concluded the pilot study described in SC/64/SH28 is the appropriate next step in method development for the provision of an absolute abundance for the Western Australian stock of humpback whales.

## 2.2 Review new information on the Arabian Sea humpback population

The Scientific Committee has in the past (most recently in JCRM 12 (Suppl) 2011 p 214), recommended further research to help address the precarious conservation status of the Arabian Sea humpback whale which is recognized as an isolated resident sub-population of humpbacks with an estimated population size of 82 (95% CI 60-111) (Minton *et al.* 2008, 2011).

Details were provided in SC/64/SH30 of small boat surveys and shore-based observations conducted in two locations off the coast of Oman: Masirah Island in October 2011, and off Hasik, Dhofar, to the south, in November 2011 and February-March 2012. Passive acoustic monitoring devices were also deployed at the southern site in November 2011 and data are currently being analysed. Acoustic monitoring is planned to continue for a full year. Though limited in geographical coverage due to weather constraints and the threat of piracy, the surveys yielded a high rate of re-sights of photo-identified individuals, demonstrating a high rate of site fidelity, particularly among males in the Hasik area. A total of 36 humpback whales was encountered across both survey sites, 33 of which were photographed and 16 were newly identified individuals, mostly recorded off Masirah Island. Feeding was observed during three encounters off Masirah Island in October 2011. No feeding was observed in the southern survey site. This contrasts with previous years' surveys at the same time of year when up to 35% of encounters involved feeding there. There were also nearly three times fewer whales encountered this year. Differences in relative density and feeding may be due to annual fluctuations in food availability as a result of variable oceanographic conditions. This also suggests that the spatial distribution and density of whales during the breeding season are potentially influenced as much by location of food sources as by preferred breeding habitats, a situation which may be unique for the species. Three mother-calf pairs were recorded in Oman during 2011 - 2012, one of which entered the newly operational multi-purpose Port of Duqm. These are the first documented records of humpback whale calves in Oman since 2000. Two mortalities were recorded in January and April 2012 respectively: an adult female floating at sea (photographed by local fishermen) and a juvenile that stranded live on a remote stretch of shoreline and was subsequently buried by the local municipal authority before scientific investigation could be conducted.



Observations of severe entanglement scarring, coastal road development, operation of a large new port at Duqm, and the planned inauguration of several fast ferry routes through known humpback whale habitat are cause for concern for the future well-being of this endangered subpopulation. Efforts are underway to highlight the population's conservation needs with local, national and regional governments as well as the general public, and progress is being made toward the formation of a network of researchers and managers responsible for the design and implementation of a Conservation Management Plan, as recommended last year (JCRM 13 (Suppl.), 2012, p. 25).

The sub-committee expressed concern over the relatively large number of strandings from this population (9 over a 12-year period). It **recommended** that, given the precarious status of the Arabian Sea humpback whale population and the potential for growth of unregulated whale watching in the region, whale watch vessel operator training workshops should be conducted with a view to promoting best practice for whale watching and to support the need for development of whale watching guidelines.

The sub-committee further noted plans to produce an updated mark-recapture estimate of population size. It **reiterated** its earlier recommendation (see JCRM 12 (Suppl) 2011 p. 214), for regular abundance surveys to be repeated, with assistance in planning and analysis from relevant experts.

It was noted that a nomination for the development of a Conservation Management Plan has been drafted by an intersessional working group formed at last year's IWC meeting for this purpose. The sub-committee **recommended** that discussions between scientists and relevant range state governments continue to further progress the development of the CMP.

### 2.3 Review new information on breeding stocks

#### 2.3.1 Breeding stock A

SC/64/SH17 reported on strandings of humpback whales off the coast of Rio de Janeiro, southeastern Brazil. The region is located to the south of the Abrolhos Bank (16°55'S, 38°50'W) and its surroundings, which corresponds to the main breeding ground of the species in the western South Atlantic. A total of 58 stranded humpback whales was recorded between 1981 and 2011 with a mean of 2.6 strandings/year and a maximum of 13 records in 2010. Stranding numbers have increased over the past 20 years, which is consistent with the population increase observed for this stock. Three cases of entanglement were found, two of these involving calves less than eight metres in body length. There were significant differences in stranding numbers between seasons. Most strandings occurred during winter and spring and correspond to when the peak abundance of the species is off Brazil. No statistical differences were found in stranding patterns across various age categories, but 33% were classified as 'dependent calf' (< 8m length). Males stranded more often than females. One out of eight stomachs examined contained beaks of the inshore squid (*Loligo sanpaulensis*) suggesting that either occasional or accidental ingestion of squids may occur in the region. Bacteriological survey of Vibrionaceae and Aeromonadaceae agents in three live stranded whales assessed indicated evidence of animal impairment that resulted in or were associated with the cause of death.

In discussion, concerns were expressed that the information is available from only a small part of the total Brazilian population, and the sub-committee **encouraged** the provision of information from the full range of animals passing along the coast.

#### 2.3.2 Breeding stock B

SC/64/SH4 described a newly-discovered humpback whale wintering ground off northwest Africa with a seasonal signature consistent with a South Atlantic stock. During a segment of a larger platform-of-opportunity sighting survey, between 21 October and 5 November 2011, humpbacks were the most frequently encountered cetacean with 21 humpback (17 confirmed and 4 probable) between Conakry and Dakar. At least five groups (29%) were adult/calf pairs, suggesting a nursery ground. The observations were six months out of phase with the nearest (and only) known breeding ground in the northeast Atlantic – the Cape Verde Islands - and there was overlap with animals in the Gulf of Guinea and the southeast Atlantic, possibly comprising the most northwestern component of BSB.

In discussion, there appears to be considerable documentation and sightings of humpback whales throughout African range states in the Eastern Atlantic corresponding with the Southern Hemisphere humpback whale breeding cycle. The sub-committee **recommended** that it would be useful to have the location and timing of the existing records of distribution, seasonality, and timing of sightings synthesized in a single map/database to show the extent of range and movements for humpback whales within a calendar year.

The sub-committee noted that digital photographs were obtained and **encouraged** the authors to approach relevant catalogue-holders to look for matches, for example with South African animals. In discussion it was also noted that there appears to be considerable documentation and sightings of humpback whales throughout African range states in the eastern Atlantic corresponding with the species' Southern Hemisphere breeding cycle. The sub-committee **recommended** that the

location and timing of the existing records of distribution, seasonality, and timing of sightings should be synthesized in a single map/database to show the extent of range and movements for humpback whales by calendar year.

Best reported that during a joint cruise between the South African Department of Environmental Affairs and the University of Pretoria in November 2011, a total of 107 biopsies were collected and numerous images obtained from humpback whales on the west coast of South Africa in the vicinity of the St Helena Bay/Saldanha Bay feeding ground. The sub-committee encourage the presentation of a report on this cruise to next year's meeting.

### 2.3.3 *Breeding stock C*

SC/64/SH3 provided a first description of humpback whale movements between breeding grounds in the Comoros Islands and coastal western Madagascar, in the western part of the Indian Ocean Sanctuary. To investigate movements and migratory routes, during 11-14 October 2011 five satellite transmitters were deployed on humpbacks off Moheli Island (12° 24'S, 43° 45'E) in the Comoros Archipelago. Three individuals were tracked successfully: mean tracking duration was 18 days (range 8-28 days); mean distance travelled was 467 km (146-749 km) and mean travelling speed  $26.7 \pm 22.3$  km/day. Although tagging occurred relatively late in the season, no whales started migrating to the Antarctic directly after tagging. One remained south of Moheli Island for the entire three weeks of deployment; the other two began travelling south a few days after tagging but only as far as coastal western Madagascar. On the way, one visited the neighbouring islands of Anjouan and Mayotte. While earlier photo-identification comparisons have suggested some interchange between the Comoros Archipelago and eastern Madagascar this is the first record of whales visiting different islands of the Comoros and western Madagascar in the same season.

Ersts *et al.* (2011) reported that humpback whale movements among breeding regions within the south western Indian Ocean (i.e., from Breeding Stock C) are poorly understood. Between 1996 and 2006, nine whales (six males and three females) were identified utilizing two breeding areas within the region: the northern Mozambique Channel, currently the breeding region for sub-stock C2, and eastern Madagascar, currently a breeding region for sub-stock C3. All documented movements were between years; however, given the close proximity of the breeding areas in question, the authors felt it is likely that within season movements also occur, as witnessed in SC/64/SH3 from two satellite tagged animals. Furthermore, population genetic comparisons have shown a lack of differentiation between individuals sampled in C2 and C3 (Rosenbaum *et al.* 2009). This lead the authors to believe, therefore, that all existing data support the conclusion that whales utilizing the regions attributed to sub-stocks C2 and C3 probably represent the same breeding sub-stock. However, it was noted there is evidence of differential utilization of certain regions in C2 and C3 by different sub-classes of individuals, such as mothers with calves (which could show fidelity to each sub-region), and the available information from Breeding sub-stock C2 only represent a small number of the islands and partially submerged banks where humpback whales have been observed.

### 2.3.4 *Breeding stock D*

The sub-committee was informed of examinations of eight neonatal humpback whales stranded on the Western Australian coast in 2011. They were among 17 humpback strandings reported that year and followed relatively large numbers of strandings (46) in 2008 (see JCRM 12 (Suppl.) 2011: 30-31, 210). That number was considerably more than in previous years (2-3 animals annually between 1989 and 2006, 13 in 2007) but there had been somewhat lower numbers since then (16 in 2010, 17 in 2011). Examinations were undertaken by personnel from the State Department of Environment and Conservation and Murdoch University; funding assistance was provided by Woodside Petroleum. All reported strandings occurred at least 1000 km south of the currently known major breeding grounds off the Western Australian northwest coast. Post-mortem examinations of three of the stranded neonates showed two were extremely malnourished. One also had severe interstitial pneumonia of an unknown cause. In addition, photographs, blubber samples, and blubber depth measurements were taken from five other strandings, so that it was possible to assess the nutritional status of eight neonates in total. The results of the visual assessment of body condition and analysis of blubber lipid content indicated that all but one of the eight neonates was in a state of severe malnutrition, and were likely to be non-viable from birth due to a lack of energy reserves and a compromised ability to thermoregulate and control buoyancy. The investigators believed that following three theories could account for the high proportion of neonate strandings in 2011:

1. increased population size and inherent high mortality rate in humpback calves.
2. parturition occurring in unsuitable areas outside the known breeding grounds due to environmental conditions.
3. mothers in a poor nutritional state giving birth to malnourished non-viable calves.

They believed theory three to be the most likely. Similar examinations are to be conducted on strandings on the Western Australian coast in 2012 and, hopefully, in future years.

### 2.3.5 *Breeding stock G*

SC/64/SH16 provided information on distribution and behavior of humpback whales from the south Pacific coast of Costa Rica. The data were collected from whale-watching boats. Whales were frequently found near the coast of Marino Ballena National Park and Isla del Caño Biological Reserve. About 35% of the whale sightings (n=208) were inside protected

waters and 64% of the sightings were mother-calf groups. This is the highest proportion of mother-calf groups so far reported for this breeding ground. Whale group size was 2.03 ( $\pm$  0.94 SD) and mother-calf groups varied from 2 to 6 individuals.

In discussion, the sub-committee's attention was drawn to the unusual number of cow/calf pods reported together in such a small population: nine groups were recorded of three or more adults with calves. The tendency for concentrations of animals to be reported in and around reserves where whale watching vessels operate is such that the distribution of sightings in SC/64/SH16 Figure 1 reflects the areas used mostly by the whale-watching vessels. The sub-committee recognised that that is currently the best way of obtaining information on distribution in a region where funding is limited, but nevertheless **encouraged** the undertaking of structured surveys to address the problem. It also **recommended** comparisons with catalogues from other areas, including breeding grounds, in the Southern Hemisphere.

SC/64/SH23 presented information on humpback identifications off Ecuador and their migratory connections to Antarctic Areas I and II. A total of 1580 individuals photographed off the coast of Ecuador were compared with 611 animals identified in the southeast Pacific in four different catalogues. There were 76 matches with the feeding areas, representing 64 individuals, all resighted in the Antarctic; most were in Area I but four were from Area II, in the Weddell Sea and east of the Antarctic Peninsula. The present study confirmed Antarctica as the main feeding ground for humpback whales found off Ecuador and suggested that feeding areas for whales identified off Ecuador may extend as far east as within Area II as the South Orkney Islands.

The sub-committee was also informed that individual animals may migrate either to the Magellan Strait or the Antarctic Peninsula, and not to both. Comparison with the catalogue of animals found off Chiloe Island, Chile, had yet to be undertaken, and the sub-committee **recommended** that it be carried out.

Information on 15 long-term resightings of humpback whales off Ecuador was reported in SC/64/SH24. One animal was resighted over a 26 year time span and provides insight into age and potential longevity of this species in breeding stock G. It also provided the earliest connection from Ecuador to Antarctica and further supports the findings that waters around the Antarctic Peninsula are the main feeding area of humpbacks migrating to Ecuadorian waters. Although there are only a low percentage of re-sighted animals between Ecuador and the Straits of Magellan, two records represent long-term observations of 17 and 21 years. Resightings of these whales confirm the Straits of Magellan as a feeding area for some whales found off Ecuador. It is likely that some whales, in particular males, are looking for opportunities to mate and move extensively in the breeding area. There may be segregation there, depending on gender, maturity and activity of the whales. The same factors may influence choice of feeding area.

The sub-committee **endorsed** the authors' plans to extend comparison of the Ecuadorian catalogue with animals from around South Georgia and in Area II for report to next year's meeting.

SC/64/O15 discussed the distribution of humpbacks in Golfo Duce, Costa Rica. With the whales' preference for coastal habitats, concentrating in specific areas to reproduce, they are exposed to anthropogenic threats such as fishing, coastal development, water pollution and marine traffic. Coastal development has increased. Observations from small boats during 2006-2012, within the gulf and the surrounding area of Osa Peninsula, showed the area is an important wintering ground for animals on the Central American Pacific coast, with the whales' distribution determined by bathymetry, water temperature and possibly currents. For example, whales seem actively to avoid areas with eddies. The area seems to be used mainly by singing adults and there were competitive groups present in depths less than 60m, suggesting that mating occurs there.

The sub-committee **endorsed** the view that spatial distribution information obtained from this study should be taken into account in establishing guidelines for appropriate management of this important Costa Rican marine coastal habitat.

### *2.3.6 Feeding grounds*

SC/64/SH21 presented new information on the abundance of humpback whales in southern Chile. The waters of Chilean Patagonian fjords and the Strait of Magellan (SM) remain today as the only recorded Southern Hemisphere feeding area for humpback whales of the breeding stock G outside Antarctic waters. This paper presented information about abundance, population structure, demographic, and reproductive trends of humpback whales from the SM feeding area using long-term data on sightings, photo-identification and molecular analysis. Between December and May, from 1999 to 2011, 969 days of land based observations and 533 vessel-days were conducted. A total of 126 individual humpback whales, comprising 36 juveniles and 90 adults were photo-identified. Humpback whales were resident in the area during summer-fall period; with a mean occupancy of 54.9 d. Only 12% of whales were sighted in one day. High levels of persistent site fidelity were found with a mean recapture rate of 82% between 2004 and 2011. The interval between the first and the last sighting ranged from one to a maximum of 12 years. The sex ratio is near parity during this period (1.08:1 male/females). The sex ratio near parity in the SM is consistent with most of the feeding aggregations. Of the 1,757 total sightings, 30 individual females across the period included records of 24 calving intervals, being two years the most frequent interval with 58.3% followed by three years interval with 16.7%. The average calving rate had considerable year-to-year variation with an average calving

rate of 0.33. Based on two females re-sighted, age of first parturition was 5 and 6 years old. Since 2004, average crude birth rate was 0.094. Mark recaptures abundance estimates have been obtained using the Chapman form of the Petersen estimator for closed populations and the Jolly-Seber estimator for open population. Closed and open models show similar tendency of steady population growth and no significant differences in abundance estimates (~130 individuals, CV=0.05) across models were found. Parity found in the sex ratio doesn't create a possible bias to this abundance estimate. This feeding aggregation is only a small fraction of the primary feeding grounds for the eastern South Pacific population but the only one using this feeding area outside the Antarctica. The small size of the humpback whale aggregation in the SM, the high site fidelity and occupancy, certainly maximize vulnerability to human activities, like commercial whale watching operations and vessel traffic. Of particular concern is the development of large-scale coal mining projects to be located on land nearby Jeronimo Channel and the middle Strait of Magellan that in the coming years will add high traffic of large ships and it raises the probability of large vessel collisions with those whales. Unfortunately, this negative impact may considerable harm this small feeding aggregation of humpback whales and has not been appropriately evaluated in the Chilean system of environmental impact assessment. Therefore evaluation of increase vessel traffic needs to be mandatory for proposed projects in this area and also the cumulative impacts of several similar projects that are planned for the area shall be assessed.

The sub-committee thanked the authors for bringing this new information forward. It noted that it could not fully evaluate the abundance estimates with the information provided in the document and encouraged the authors to presented more details in the methodology used to compute these estimates in the future. In response to a question, it was noted that the population in the region of the Magellan Strait is likely small. The sub-committee expressed concerns regarding the potential for ship strikes and habitat displacement if the coal mining development results in a substantial increase of ship traffic in the region. The sub-committee **recommended** that potential impacts are assessed and mitigation measures are adopted when needed.

#### **2.4 Antarctic Humpback Whale Catalogue**

SC/63/SH1 provided an update on the Antarctic Humpback Whale Catalogue (AHCW), maintained by the College of the Atlantic (COA). During the contract period, 461 photo-identification images representing 391 individual humpback whales from Antarctic and southern hemisphere waters were catalogued. Images were submitted by 56 individuals and research organizations. These submissions bring the total number of catalogued whales identified by fluke, right dorsal fin/flank and left dorsal fin/flank photographs to 4635, 414 and 409 respectively. Matches made during the contract period to previously sighted individuals include re-sightings between breeding stock G and the Antarctic Peninsula (2), between breeding stock G and Chile (1), and between breeding stock E and breeding stock E3 (1). Within-region re-sightings were identified in the Antarctic Peninsula (3), Chile (4), breeding stock E (3), breeding stock E1(2), breeding stock E3 (4), and breeding stock C2 (1). Opportunistic data represent a significant portion of the AHCW. Progress continues in efforts to stimulate submission of opportunistic data from eco-tourism cruise ships in the Southern Ocean and from research organizations and expeditions working throughout this region and the Southern Hemisphere.

The sub-committee thanked the authors for their hard work and recognized the importance of this catalogue to the work of the sub-committee. The sub-committee **recommended** that the AHCW continue. This item has financial implications to the sub-committee (see Item 5.1).

### **3. ASSESSMENT OF SOUTHERN HEMISPHERE BLUE WHALES**

#### **3.1 Review new information**

##### *3.1.1 Photo-identification catalogues*

SC/64/SH8 provided an update on the Antarctic Blue Whale Photo-Identification Catalogue (ABWPIC). This catalogue includes photographs collected during 20 years of IWC IDCR/SOWER cruises (1987-88 to 2009-10). In 2011 and 2012 the photographs of eight new whales and one re-sighted whale (2007-2010) were added to the catalogue by the contribution of photographs from collegial scientists working in the Antarctic. Currently the catalogue contains a total of 227 identified whales. Seven whales were re-sighted in multiple years. Distances between inter-year sighting locations ranged from 19 km to over 5000 km. Mark-recapture analysis of Area III in the 3-year time period 2004/2005-2006/2007 yielded estimates of abundance ranging from 818 to 1097 whales. This estimate is a large portion of the total abundance of Antarctic blue whales (Branch *et al.* 2007).

The sub-committee welcomed this update and recognised that the data have also been submitted to the Southern Hemisphere Blue Whale Catalogue. Photographs of blue whales from the JARPA and JARPA II programmes have not yet been included in the ABWPIC but have been submitted to the IWC Secretariat. The sub-committee **reiterated** previous recommendations (IWC, 2008) that the photographs are added to the ABWPIC and reconciled. This is an item of financial implication to the sub-committee (Item 5.2, below) and the sub-committee **recommended** that this work be funded.

SC/64/SH20 presented an update on the Southern Hemisphere Blue Whale Catalogue (SHBWC) that holds photo-identification catalogues of research projects from major areas off Antarctica, Australia, Eastern South Pacific and the Eastern Tropical Pacific. The paper also presented preliminary results of 2011-2012 catalogue comparisons between the eastern South Pacific Ocean, Eastern Tropical Pacific Ocean (ETP) and Southern Ocean. The Antarctic sub-catalogue of the SHBWC includes photographs of 227 individual blue whales collected during IWC IDCR/SOWER surveys from 1987-1988 to 2008-2009 and covers all six IWC Management Areas (SH8). The eastern South Pacific Ocean sub-catalogue includes photographs of 21 individual blue whales collected during a 1997/98 survey off Chile and the catalogue of Centro de Conservacion Cetacea with 300 individuals photographed off southern Chile between 2004 and 2009. The ETP sub-catalogue includes photographs of 11 whales near the Galapagos Islands, 23 whales in the oceanographic cold equatorial tongue that extends westward from the Galapagos, 18 whales in Peruvian waters, and 32 whales at the Costa Rica Dome that were contributed by the SWFSC/NOAA collected during various years from 1992 to 2009. Not all individuals have been photographed from both sides and a total of 822 and 826 individual blue whales photographed from left and right sides respectively are held by the SHBWC for those areas. Comparisons of individual photographs were examined separately by left- and right- side. Left-side comparisons have been completed and right-side comparisons are underway for ETP and the other areas. Comparisons of Southern Ocean and eastern South Pacific are almost complete by left side and right side has not started yet. To date, no matches have been found. Although no re-sightings have been found between those regions in the SHBWC, there are re-sightings both within Chile and in the Southern Ocean. However, none of the 84 whales photographed off ETP have been re-sighted within or outside of the ETP.

Chilean blue whales represent a unique population and are likely an unnamed subspecies (Branch *et al.* 2007). The comparison results obtained so far represent additional support that Southern Ocean and eastern South Pacific blue whales are distinct populations as no Chilean blue whales have been resighted in the Southern Ocean.

The authors noted that although no breeding ground has been documented for blue whales in the Southern Hemisphere, it would be expected that blue whales feeding in either Southern Ocean or eastern South Pacific would use low latitudes in the region near the Equator or maybe the ETP for their breeding grounds. However, at this time there is no evidence of exchange between ETP and the eastern South Pacific or the Southern Ocean. This is consistent with other data (satellite tracking, acoustic, and photo-identification) linking the ETP blue whales to blue whales off Baja California, Mexico and California. Therefore, the breeding grounds of Southern Hemisphere blue whales remain largely unknown.

The sub-committee noted that evidence of a possible breeding ground for Antarctic blue whales had been presented at an earlier meeting (SC/50/CAWS14).

The sub-committee **encouraged** contributions of regional catalogues not yet in the SHBWC (e.g. eastern and western Australia) to facilitate full reconciliation of the catalogue for the Southern Hemisphere blue whales. The sub-committee **recommended** continued support for the SHBWC. This is an items of financial implication (Item 5.2, below).

### 3.1.2 Antarctic blue whales

#### 3.1.2.1 METHODOLOGICAL DEVELOPMENT

SC/64/SH11 summarised two voyages conducted by the Australian Antarctic Division off south-eastern Australia to refine acoustic tracking methodologies to address the aims of the Southern Ocean Research Partnership's Antarctic Blue Whale Project. The primary aim of this project is to estimate the circumpolar abundance of Antarctic blue whales (*Balaenoptera musculus intermedia*) using mark-recapture methods. Such methods require a relatively high encounter rates and this could be improved using passive acoustic methods. These two three-week surveys targeted a region within the Bonney Upwelling (141.0-143.0°E and 38.0-39.5°S), along the south-east coast of Australia, an area known to be a summer (November-May) feeding area for pygmy blue whales (*Balaenoptera musculus brevicauda*). Of the six weeks allocated across both surveys, weather allowed for a total of 20 survey days (ten for each survey). The passive acoustic tracking system, using DIFAR sonobuoys, operated continuously during the voyages recording nearly 500 hours of audio, while acousticians processed over 7000 blue whale calls all in 'real-time'. During the voyages 33 vocalising blue whales were followed via acoustic tracking and of these 28 resulted in visual sightings of groups of one or more whales, giving a combined acoustic success rate of 85%. Sighting effort was 785 nautical miles during the January voyage and 670 nautical miles during March voyage, over 127 and 105 hours, respectively. The first voyage yielded 37 sightings of blue or like-blue whales; a total of 70 animals. During the second voyage there were 15 sightings of blue or like blue whales; 34 animals in total, in addition to three sightings of unidentified large baleen whales. Photo-identification during the first voyage identified 24 individual blue whales and coincidentally 24 individuals were also identified during the second voyage. One animal was sighted on both voyages. These data will be submitted to the Southern Hemisphere Blue Whale Catalogue. Other noteworthy sightings include groups of Shepherd's beaked whales (*Tasmacetus shepherdi*) on both surveys; a sei whale (*Balaenoptera borealis*) in the first survey; and a fin whale (*Balaenoptera physalus*) in the second survey.

In reply to a question, the author said there were some blue whales that had been seen but not heard.

SC/64/SH12 summarised the methodological development of the use of DIFAR sonobuoys for real-time tracking of blue whales. Because passive acoustic tracking relies on the use of complex electronic systems, it is important to understand the capabilities and limitations of the hardware and software that comprise the system to understand what constitutes sensible use. A DIFAR (Directional Frequency and Recording) sonobuoy contains 3 hydrophones, a magnetic compass, signal processing circuitry, and a VHF (very high frequency) radio transmitter. Sonobuoys send signals via VHF radio to a recording device; simultaneously an operator listens to the incoming audio data and watches a computer visualisation of acoustic signal characteristics and bearings in real-time. Selected sounds, such as whale vocalisations, can be identified and further analysed to obtain information such as the absolute sound pressure level and the direction to the sound source. The range of the VHF reception enables a baseline for determining direction of targets of up to 40km. The accuracy and precision of the DIFAR bearings are particularly important for real-time tracking of whales. The magnetic compass in each sonobuoy has a nominal accuracy of  $\pm 10^\circ$ . For localisation of targets, magnetic bearings must be corrected for local magnetic declination either using a chart, or by using a measurement to a target at a known location, e.g., the research vessel. Trials demonstrated that the distance travelled to reach most acoustic targets was typically under 10km. However 12 targets further than 10 km indicate that acoustic surveys may offer increased effective range over purely visual surveys of blue whales. The two target distances of over 60 km hint at the potential of acoustic tracking over longer distances as would be expected to occur when targeting Antarctic blue whales in the Southern Ocean.

SC/64/SH14 reported methodological development for estimating relative abundance from historic Antarctic whaling records. Catch per unit effort data (CPUE) are often the only form of data available used to infer patterns of distribution and abundance of exploited populations depleted by historic whaling. Information derived from CPUE underestimates variations in relative abundance when effort data is only measured in total operating days. Gross effort includes both searching time and handling time, but it is only the first of these times that is useful in deriving an index of relative abundance. An expectation maximisation (EM) method is developed for improving the linearity of the relationship between relative abundance and CPUE by estimating the searching time. The searching time is found by subtracting an estimate of time lost due to handling from the gross effort. An additional correction is required if handling time can occur past the end of the operating day. An EM algorithm is used to combine maximum likelihood estimates of the handling time with the expected additional operating time due to handling the last catch of each day. Simulation tests show that the method leads to estimates of catch per unit of searching time (C/CSW) that are much closer to proportionally related to local density than gross CPUE. However, the method does not produce unbiased estimates of handling time and some non-linearity can remain in the relationship between local density and catch per unit of searching time.

In discussion, it was noted that once completed and accepted by the Scientific Committee the datasets and script referred to in SC/64/SH14 will be submitted to the IWC Secretariat.

SC/64/SH26 presented an exploration into what encounter rates are plausible using acoustic-assisted tracking of whales, as opposed to a traditional visual-only survey (such as IDCR/SOWER). The problem was approached in two ways: a simplified abstract calculation based on area covered and a discrete-time individual-based simulation of whales and survey vessel. Reassuringly, both approaches gave similar results, and when compared to results from pilot surveys in temperate waters off the south-east coast of Australia (described in SC/64/SH11), gave numbers of encounters close to those observed. Applying the passive acoustic simulation methods to the Antarctic, a range of potential encounter rates were derived, which were heavily dependent on longitudinal region, as well as the assumed population growth used. As a general guide, across the circumpolar region, it appeared unlikely that the whales-marked per planned survey day would exceed four. On the other hand, it seemed that a rate of at least one whale per planned survey day could be expected. Given the lack of data, and the number of assumptions, abstractions, and approximations required in this simulation exercise, the authors stress that the expected number of daily encounters of Antarctic blue whales estimated in these simulations should not be considered accurate or precise. However, these simulation results provide a framework to investigate the performance of an acoustically assisted mark-recapture survey for blue whales.

SC/64/SH10 presented a significant advancement on the feasibility study of methods to obtain a new estimate of circumpolar abundance of Antarctic blue whales presented at last year's meeting (SC/63/SH3) and addressed the recommendations of the SC. This paper also synthesised the results of the studies presented in SC/64/SH11, SC/64/SH12, SC/64/SH14 and SC/64/SH26. The previous study (SC/63/SH3) demonstrated that a line-transect approach alone is not a realistic option to obtain a precise circumpolar abundance estimate of Antarctic blue whales. This study was expanded, via an exploration of a mark-recapture/line-transect survey hybrid model. Simulations were used to test a mark-recapture approach in tandem with techniques to boost encounter rates. These techniques included using the seasonality and location of historical sightings (in particular, IDCR/SOWER sighting data), acoustic detections made during various IWC-SOWER surveys, and historical catch data to target 'hotspots' distributed around the coast of Antarctica that may host higher densities of Antarctic blue whales. Also reviewed are recent developments in acoustic tracking that could yield increased encounter rates over visual survey alone. To minimise heterogeneity in capture probabilities across the population as a whole, mark-recapture surveys should target putative hotspots and make use of passive acoustic tracking to increase

encounter rates. In light of all of these results, the authors conclude that given a reasonable level of effort it would be possible for mark-recapture surveys to provide a viable estimate of circumpolar abundance for Antarctic blue whales within a ten-year period.

In discussion, the sub-committee recognised that the longer-term timeline to estimate abundance of Antarctic blue whales is more appropriate and logistically feasible than the shorter periods considered earlier in the project's development. It was noted that possible confusion remaining in regards to the 'Year of the Whale' concept will be addressed by the SORP Steering Committee in the SC and Commission.

The sub-committee welcomed the suite of papers linked to the Antarctic Blue Whale Project and the considerable advancement in the project's development following IWC63 through further analyses of empirical data, simulation modelling and the successful at-sea trials of acoustic methodologies. It was suggested that further mark-recapture simulations studies may be valuable to investigate the effects of variability in effort between years within the suggested ten year timeframe and also to investigate the interaction between spatial variability in effort and possible population structure. This simulation could assess the consequences of only targeting 'hotspots' and the potential heterogeneity in capture probability potentially generated through this approach.

Further the sub-committee **encouraged** ships contributing to the Antarctic Blue Whale Project should, whenever possible, also collect environmental data for habitat modelling and data on other whale species sighted. In some circumstances environmental data can be collected through remote sensing but this is often problematic around Antarctica due to extensive cloud cover. Gliders and floats may provide another opportunity to collect high resolution water column data.

#### 3.1.2.2 PLANNING OF FUTURE RESEARCH

SC/64/SH13 presented a preliminary voyage plan for an Australian Government funded voyage which will be a significant contribution to the Southern Ocean Research Partnership's (SORP) Antarctic Blue Whale Project. The aim of the Antarctic Blue Whale Project is to develop technologies and collect data that will ultimately deliver a new circumpolar abundance estimate for Antarctic blue whales (*Balaenoptera musculus intermedia*). The project will also improve understanding of population structure, linkages between breeding and feeding grounds, and characterise the behaviour of blue whales in their Antarctic feeding grounds. The voyage will begin in early February 2013, be between 42 and 50 days duration, departing from and returning to Nelson, New Zealand. The voyage will focus on blue whales in waters west of the Ross Sea (i.e., 135-175°E), an area that has been associated with higher densities of blue whales, according to analyses of historical catch data, IDCR-SOWER sighting data, and IDCR-SOWER sonobuoy deployments. Other 'hotspots' were considered for this voyage including the area from the Davis Sea and west across the top of Prydz Bay (i.e., 60-100°E), and the Haakon VII Sea (i.e. 10°W - 30°E) but transit times from Australia or New Zealand precluded these options. The plan will be further developed and review once the project management structure for the Antarctic Blue Whale Project is established which includes the formation of technical committees on passive acoustics, individual identification, and survey design.

In discussion, the sub-committee emphasised the importance of collecting opportunistic data on other whales (sightings, faecal collection, biopsies) and environmental data, but recognized the value of clear priorities particular when the number of days 'on-site' in good weather can be few, even for longer Antarctic voyages.

The South African Blue Whale Project (SC/64/O16) is intended to take advantage both of the known high concentrations of Antarctic blue whales in summer immediately south of the African continent (arguably the highest densities anywhere in the Southern Ocean), and the strong indication from historical catches that there may be a breeding ground for the species off the west coast of Africa in winter. Its objectives are to initiate a long-term monitoring programme of blue whales in the Antarctic sector east of the Greenwich meridian, coupled with investigations of their seasonal pattern of abundance at lower latitudes. Acoustic technology will be combined with traditional line transect sighting survey and mark-recapture methodology to study the distribution, abundance and movements of blue whales in the south-east Atlantic. The intention is that this will form the first phase of an acoustic monitoring programme to investigate population trend, and will form a component of an integrated circumpolar research programme on Antarctic blue whales under the auspices of SORP. The study is currently a joint one between the Mammal Research Institute of the University of Pretoria and the Applied Physics Laboratory of the University of Washington, and has received funding for 3 years from the South African National Antarctic Programme, starting in 2012/13. Three Automatic Acoustic Recorders are on order and will be deployed along the ice edge in summer and redeployed along the west coast of southern Africa in winter. The devices are rated to 350 m and will be attached to a sea-floor mooring via an acoustic release: they can record for at least a year at a sampling rate of 25 mins out of every hour. Sixteen days research time have been requested during the 2012/13 relief voyage of the South African polar supply ship SA Agulhas II to undertake the first high latitude deployment and associated survey, but this ship's time is allocated on a competitive basis with other user groups and at this time there is no indication of what if any time will be allocated for this project. This uncertainty does not affect the low latitude deployments to the same extent, so even if no high latitude work is possible this summer, this period could be used to extend low-latitude coverage to almost twelve months of the year. There may be better opportunities to work in the Southern Ocean in 2013/14. A proposal for one

of the team to receive training in AAR deployment during a cruise off Greenland this summer has been submitted to the SORP steering committee for its consideration (SC/64/O17).

In discussion it was clarified that although data valuable to the SORP Antarctic Blue Whale Project will be collected on this voyage (photo-ID and biopsy samples) the project is more closely linked with another SORP project 'Acoustic trends in abundance distribution and seasonal presence of Antarctic blue whales and fin whales in the Southern Ocean (see SC/64/O13). It was noted that sightings and biopsy data from the JARPA program can also contribute to the assessment of Antarctic blue whales.

SC/64/SH25 proposed a project on the genetics of Antarctic blue whales. The Antarctic blue whale population was reduced to less than 1% of its original abundance, to an estimated 400 individuals, due to intense exploitation by the commercial whaling industry. The impact of this bottleneck on genetic diversity remains unknown. The contemporary Antarctic blue whale has been described by a relatively high mitochondrial DNA (mtDNA) haplotype diversity, and may have escaped a greater loss of genetic diversity due to its long life span, overlapping generations and the brief period of the bottleneck. The impact of 20th century commercial whaling on genetic diversity could be explored through a comparison of historic and contemporary genetic diversity. The authors requested continued access to biopsy samples of blue whales collected on Antarctic feeding grounds during IDCR and SOWER cruises and funding to assist in marker development for bone samples collected from whaling stations from South Georgia. This would require transfer of additional DNA from SWFSC as all previous DNA has been expended in completing published project (Sremba *et al.* 2012). We propose to develop and target single nuclear polymorphisms (SNPs) within the contemporary Antarctic blue whale which the identification of target SNPs in the contemporary Antarctic blue whale population and historic South Georgia Antarctic blue whale population to gauge a loss of genetic diversity.

The subcommittee **recommended** that access to the samples continues for this work and encourages that further sampling in South Georgia.

### 3.1.3 Pygmy blue whales

SC/64/SH27 presented a study on the identity of blue whales that are regularly sighted in the Geographe bay region of western Australia. There are two currently recognised subspecies of blue whale (*Balaenoptera musculus*) in the Southern Hemisphere: the Antarctic blue whale (*B. m. intermedia*) and the pygmy blue whale (*B. m. breviceauda*) that are generally found in polar and temperate waters, respectively, during the austral summer feeding season. Blue whales are visible from the coast of south-western Geographe Bay in Western Australia very early in the feeding season and appear to follow the coastline or bathymetry polewards. The origin and destination of these blue whales is uncertain. They may be pygmy blue whales migrating to the Bonney Upwelling Australian feeding ground, other undescribed feeding ground(s), or may be individuals from the Antarctic blue whale subspecies migrating to polar feeding grounds. Here we present our progress in investigating the subspecies and population identity of Geographe Bay blue whales using 20 microsatellite loci and mitochondrial DNA control region sequences. Thirteen biopsy samples from blue whales utilising Geographe Bay were collected from November to December in 2009 and 2010. These were compared to samples from the Australian pygmy blue whale feeding aggregations (n = 109) and Antarctica collected through IWC IDCR/SOWER cruises (n = 152). Preliminary results based on measures of genetic structure indicate that Geographe Bay blue whales were all of the pygmy subspecies. Further samples from Geographe Bay are required to clarify whether these blue whales have fine scale genetic differentiation to blue whales utilising the Australian feeding aggregations.

The subcommittee welcomed this paper and acknowledged its contribution to the understanding of pygmy blue whale distribution and migration behaviour in Australian waters. In discussion, it was noted that existing data (e.g. satellite tagging, Gales *et al.*, 2010) provides support to an Australia-Indonesian population as suggested by Branch *et al.* (2007). It was also noted that sightings of blue whales off Eden, New South Wales, have been reported in 1999, 2000, 2002, 2005-2008 and 2011 including feeding events in 1999 and 2000 and a mother with a calf in 2000. The identity of the blue whales sighted off Eastern Australia remains unclear.

### 3.1.4 Chilean blue whales

Galletti Vernazzani *et al.* (in press) described the results of a collaborative research program (the Alfaguara Project) conducted by Centro de Conservacion Cetacea on Chilean blue whales (*Balaenoptera musculus*). From 2004 to 2010, eight aerial and 85 marine surveys were conducted off Isla de Chiloe, southern Chile. A total of 363 individual blue whales were photo-identified. Approximately 20% of all catalogued individuals were resighted within the same season and 31% were resighted between years. Observations on feeding and social behaviour also were recorded. Recaptures of photo-identified individuals from other areas to the north and south of the main study area support the hypothesis that the feeding ground off southern Chile is extensive and dynamic. Additionally, an individual first seen in Isla de Chanaral, northern Chile was resighted about two month later off Isla de Chiloe, showing connections between those two areas. Blue whale distribution off southern Chile was assessed and relative abundance, using sighting per unit effort and kernel density estimators was



obtained. The high overall annual return and sighting rates highlight the waters off northwestern Isla de Chiloe and northern Los Lagos as the most important aggregation areas currently known for this species in Chile and one of the largest in the Southern Hemisphere.

SC/64/SH18 provided an update on the 2012 blue whale field season that reported the occurrence of a shift in blue whale distribution during 2012 in the southern Chile feeding area (Isla de Chiloe) and document an additional feeding aggregation of blue whales in northern Chile (Isla de Chanaral). A total of 39 days of land-based observation, 9 marine surveys and 2 aerial surveys were conducted off southern Chile. The average number of whales sighted per day from land-based observations and from the boat decreased considerably in 2012 compared to previous years and also, the encounter rate decreased through the season in contrast to previous year, when it increase. In 2012, we recorded the northernmost blue whale sighting off South Araucania/Los Rios region where no sightings were recorded in previous years. Compared to previous years, blue whale distribution shifted to the Isla de Chiloe area, about 130 km to the north in 2012. In situ average sea surface temperature (SST) off northwestern Isla de Chiloe significantly increased between 2005 and 2012 and reached its maximum in 2012 with 22°C. The summertime SST remotely sensed imagery for the Isla de Chiloe area indicated that the warm water typically found offshore during the summer months intruded into the coastal area, where water is normally cold due to upwelling processes in the Humboldt Current. Southern sunfish, a species from warm and tropical waters in the Southern Hemisphere were recorded off Isla de Chiloe between January and March 2012, when water temperatures were higher than in past years. This was the first year we recorded sunfish off northwestern Isla de Chiloe. Compared to previous years, marine bird species richness and abundance were lower. Due to the low numbers of blue whales off Isla de Chiloe, four marine surveys were conducted in northern Chile around Isla de Chanaral (29°01'S - 71°37' W) in late February. Blue whales sightings were documented and feeding behavior. The in-situ SST was about 3-4° C lower than off Isla de Chiloe. Our results indicate that there appears to be more than one feeding area for blue whales in Chile. The relatively small number of blue whales sighted per day off Isla de Chanaral compared to the southern Chile feeding area (off Isla de Chiloe) suggests that Isla de Chanaral may be a secondary feeding area for the population or part of another larger feeding area north of Isla de Chiloe. Therefore, it is critical to continue to monitor the presence of blue whales in this northern blue whale feeding habitat. Blue whales were sighted around Isla de Chanaral during summer 1998, but no blue whales were observed in this region in the following summer. Also, it appears that the 1997-98 and 2012 (this report) shifts in blue whale distribution and the occurrence of southern sunfish off Isla Chiloe are a consequence of oceanographic events like ENSO or other anomalous intrusions of warmer water into the Humboldt Current. However, SST alone was not a good predictor for blue whale encounter rates in southern Chile so more sophisticated models including chlorophyll-a and other environmental variables should be investigated to better understand blue whale distribution and its shift under different oceanographic and climate scenarios.

The sub-committee recognized the value of such long-term datasets for understanding blue whale populations and **recommended** that they continue.

SC/64/SH19 presented an abundance estimate of Chilean blue whales by mark-recapture and line-transect techniques. Mark-recapture analyses used Centro de Conservacion Cetacea catalogue comprised mostly by blue whales photographed off Isla de Chiloe from 2004 to 2010 but also includes one opportunistic sighting from northern Chile. After quality selection for mark-recapture analysis, 334 encounter histories of individuals photographed by left side were used. Estimates of abundance were calculated using the software MARK, assuming both closed and open population models. Data from 2004 and 2005 were pooled because of small sample sizes. The closed capture model, time depended with equal captures and sighting rates best fit the data. However, the full closed captures with heterogeneity model, also time dependent and with equal captures and sighting rates, had a small difference in AIC. So there is actually no evidence for heterogeneity of capture probabilities in the whales using the Isla de Chiloe feeding area. These models provided population size estimates of 691 individuals and 714 individuals, respectively. Under the open population assumption, the POPAN model had a significantly smaller AIC when apparent survival rate was constant through time. The abundance estimate for the super-population was 917 individuals and apparent survival ( $\phi$ ) of 0.94. High resighting probability for blue whales off Isla de Chiloe and connections with other feeding areas in northern Chile indicates that they use other areas in Chilean waters in addition to Isla de Chiloe. Therefore, these mark-recaptures abundance estimates are likely to represent the entire Chilean blue whale population. Line-transect abundance estimates were obtained using data from aerial surveys off southern Chile feeding ground in 2007, 2009 and 2010, and program DISTANCE 5.0. Flat windows do not allow observers to see animals on trackline, so perpendicular distances were investigated and data was left truncated at 900m. Detection probability function was estimated using three years of pooled data to increase number of sightings and precision. Density, encounter rate and cluster size was estimated separately for each year. Various models were tested to distances and the model that best fit the detection function based on its minimum AIC was the uniform function with cosine adjustment. In aerial surveys, animals are missed when they are beneath the surface and therefore the detection probability on the trackline,  $g(0)$ , is not equal to 1 and a correction factor was introduced using in-situ measurements. Abundance estimates with correction factor for  $g(0)$  were 97 (CV=0.51), 154 (CV=0.32) and 163 (CV=0.39) respectively. Survey coverage areas are not the same through the years and therefore estimates are not directly comparable. These estimates should be considered as abundance

estimates of blue whales in the feeding ground off southern Chile rather than abundance estimates for the blue whale population in Chilean waters. Estimates from aerial surveys indicate that the number of animals present within the southern Chile feeding ground is six to ten times less than the abundance estimates obtained for Chilean population through mark-recapture techniques. Therefore, there must be one or more additional areas where Chilean blue whales are found during the austral summer-autumn. One of those areas might be the recently reported feeding aggregation off Isla de Chanaral (SH18). Similar situations appear to happen in Australia and Antarctic, so it seems blue whale observations in all Southern Hemisphere regions suggest that animals aggregate on several different feeding areas.

The sub-committee welcomed these studies and the associated abundance estimates. It recognised that the area covered by the line-transect survey does not include the entire range of the population and so will underestimate the total population size. The mark-recapture approach provides greater estimates of population size but if there is structure between the feeding groups and all are not sampled then the mark-recapture approach may also underestimate the total population size. The sub-committee **encouraged** the authors to revisit the MR analysis to ensure accuracy in the number of estimated parameters for time-dependent models and to conduct Goodness of Fit testing to identify the most appropriateness model for this population.

#### **4. REVIEW NEW INFORMATION ON OTHER SPECIES**

SC/64/SH2 reported on a sighting of a large school of fin whales on 30 May 2010 approximately 2,810 km west of continental coast of Chile (21°27'S, 97°34'W). This sighting supports the limited available information that fin whales migrate to open ocean in sub-tropical waters in the austral fall-winter.

SC/64/SH7 reported on the population structure of Bryde's whales along the east and west coasts of South America using mtDNA. Review of this document was carried out by the Stock Definition working group and their conclusions are found in Annex I, item 3.2.1.

SC/64/SH9 reported on a fisheries survey on board RV *Polarstern* conducted by Germany under the auspices of CCAMLR. The cruise took place in the western Scotia Sea (Elephant Island - South Shetland Island - Joinville Island area) during 13 March - 9 April 2012. During this expedition, an opportunistic marine mammal survey was conducted on 26 days resulting in 295 hrs on effort. A total of 248 sightings were collected, including three different species of baleen whales, fin whale (*Balaenoptera physalus*), humpback whale (*Megaptera novaeangliae*), and Antarctic minke whale (*Balaenoptera bonaerensis*) and also killer whales (*Orcinus orca*). More than 62% of the sightings recorded were fin whales (155 sightings), which were mainly related to the Elephant Island area (116 sightings). Usual group sizes ranged from one to five individuals. Larger groups of more than 20 whales, and on two occasions more than 100 individuals, were observed as well. These large pods of fin whales were observed feeding in shallow waters (< 300 m) on the north-western shelf off Elephant Island where large aggregations of Antarctic krill (*Euphausia superba*) occurred.

SC/64/BC2 reported on a stranding of a sei whale, *Balaenoptera borealis*, in May 2001 on a sandy beach in Papaturro Beach, Salinas Bay, Guanacaste Province (Northwestern Pacific coast, ~11°N). The animal was judged to be a female because of its large size (18 m in length). The whale beached at around 6:00 am and died close to 12:00 pm. The skin on the ventral region was scraped and there were several barnacles of the genus *Xenobalanus* (Crustacea: Cirripedia: Balanomorpha) attached to the dorsal fin. The cause of death could not be determined. This is the first reported stranding of this species in the Eastern Tropical Pacific (ETP) where this species is very rare (has never been seen in the cruises of the SWFSC/NOAA ships, Pitman, pers. com.), and the second in the Pacific coast of the American Continent. The closest known stranding to the one described here occurred in Chile.

In discussion, it was noted that given the rarity of sei whales in the ETP, this individual could have come from the Southern Hemisphere. In response to a question, the authors noted that no tissue samples that could be used to help clarify stock structure were collected. It was also noted that this individual seemed severely emaciated and that protocols to collect standardized data and samples from stranded animals could help clarify the significance and potential cause of these events. In this regards, the sub-committee was informed that the United Nations Environmental Program has conducted workshops on strandings and stranding responses in the wider Caribbean Area.

#### **5. WORK PLAN AND BUDGET CONSIDERATIONS**

##### **5.1 Humpback whales**

The work plan for the assessment of Southern Hemisphere humpback whales is described in Table 2 and will be furthered by an intersessional working group detailed below. This involves an item with financial implications for the sub-committee. A proposal for conducting further population assessment modeling of breeding stocks D, E and F is presented in Appendix 4. This work will be conducted by Müller, Johnston, and Butterworth and the total budget request is £3,000.

An additional item with financial implications is the continuation of the Antarctic Humpback Whale Catalogue. A total of £15,000 is proposed by Allen, Carlson, and Stevick to continue this work for the period 2011-2012 (Appendix 5).

Group	Terms of Reference	Membership
(1) Assessment of Southern Hemisphere Humpback Whale Breeding stocks D, E and F (Working Group)	The tasks are to obtain available data sets by 31 December 2012, develop movement models, run the assessment models and present the results at the next SC meeting	Müller (convenor), Butterworth, Double, Jackson, Kaufman, Palka, Pastene, and Zerbini.

## 5.2 Blue whales

The sub-committee **recommended** that the JARPA blue whale photo-identification catalogue be compared to the Antarctic blue whale catalogue and that this work will be conducted by Olson with a total budget request of £3,000 (Appendix 6).

The sub-committee also **recommended** that work continue on the Southern Hemisphere Blue Whale Catalogue (SHBWC) and that this work will be conducted by Galletti with a total budget request of £3,000 (Appendix 7).

## 6. ADOPTION OF THE REPORT

The report was adopted on 19 June 2012 at 18:13.

### REFERENCES

- Branch, T.A. and 41 co-authors. 2007. Past and present distribution, densities and movements of blue whales *Balaenoptera musculus* in the Southern Hemisphere and northern Indian Ocean. 2007. *Mammal Rev.* 37(2): 116-175.
- Branch, T.A. 2007. Abundance of Antarctic blue whales south of 60°S from three complete circumpolar sets of surveys. *J. Cetacean Res. Manage* 9(3): 253-62.
- Bannister and Hedley (2001) Southern Hemisphere group IV humpback whales: their status from recent aerial survey. *Memoirs of the Queensland Museum* 47(2): 587-598.
- Branch (2011) Humpback abundance south of 60°S from three complete circumpolar sets of surveys. *JCRM Special Issue 3*: 53-70.
- Chaloupka *et al.* (1999) Estimating seasonal abundance and survival rates of humpback whales in Hervey Bay (east coast Australia). *Marine Ecology Progress Series* 184: 291-301.
- Chittleborough (1965) Dynamics of two populations of the humpback whale, *Megaptera novaeangliae* (Borowski). *Australian Journal of Marine and Freshwater Research* 16(1): 33-128.
- Constantine *et al.* (2012). *Marine Ecology Progress Series* 336:275-289.
- Ersts, P.J., Pomilla, C., Kiszka, J., Cerchio, S., Rosenbaum, H.C., Vely, M., Razfindrakoto, Y., Loo, J.A., Leslie, M.S., and Avolio, M. 2011. Observations of individual humpback whales utilizing multiple migratory destinations in the south-western Indian Ocean. *African Journal of Marine Science* 33(2): 333-338.
- Forrester *et al.* (2011) Long term trends in abundance of humpback whales in Hervey Bay, Australia. *JCRM Special Issue 3*: 237-242.
- Gales, N., Double, M.C., Robinson, S., Jenner, C., Jenner, M., King, E., Gedamke, J., Childerhouse, S. and Paton, D. 2010. Satellite tracking of Australian humpback (*Megaptera novaeangliae*) and pygmy blue whales (*Balaenoptera musculus brevicauda*). Paper SC/62/SH21 presented to the IWC Scientific Committee, June 2010, Agadir, Morocco (unpublished). 9pp. [Paper available from the Office of this Journal].
- Galletti Vernazzani, B., Carlson, C.A., Cabrera, E. and Brownell, J.R. Chilean blue whales off Isla Grande de Chiloe, 2004-2012: distribution, site-fidelity and behaviour. *J. Cetacean Res. Manage*: 12pp.
- Hedley S.L., Dunlop R.A., Bannister J.L. (2011) Evaluation of WA Humpback surveys 1999, 2005, 2008: Where to from here? In: Report to the Australian Marine Mammal Centre on work done to 6th May, 2011, p. 28.
- Hiby, L. 1999. The objective identification of duplicate sightings in aerial survey for porpoise. pp. 179-189. In: G.W. Garner, S.C. Amstrup, J.L. Laake, B. F.J. Manly, L.L. McDonald, and D.G. Robertson (eds.) *Marine mammal survey and assessment methods*. Balkema, Rotterdam. 287 pp.
- Hiby, L. and Lovell, P. 1998. Using aircraft in tandem formation to estimate the abundance of harbour porpoise. *Biometrics* 54: 1280-1289.
- International Whaling Commission. 1998. Report of the Scientific Committee. Annex G. Report of the sub-committee on Comprehensive Assessment of Southern Hemisphere humpback whales. *Rep. int. Whal. Commn* 48:170-82.
- International Whaling Commission. 2007. Report of the Scientific Committee. Annex H. Report of the Sub-Committee on Other Southern Hemisphere Whale Stocks. *J. Cetacean Res. Manage. (Suppl.)* 9:188-209.
- International Whaling Commission. 2010. Report of the Scientific Committee. Annex H. Report of the Sub-Committee on Other Southern Hemisphere Whale Stocks. *J. Cetacean Res. Manage. (Suppl.)* 11(2):218-51.
- International Whaling Commission. 2012. Report of the Scientific Committee. Annex H. Report of the Sub-Committee on the Other Southern Hemisphere Whale Stocks. *J. Cetacean Res. Manage. (Suppl.)* 13:192-216.
- Johnston and Butterworth. 2005. A Bayesian assessment of the west and east Australian breeding populations (stocks D and E) of Southern Hemisphere humpback whales. Paper SC/57/SH15 presented to the IWC Scientific Committee, June 2005, Ulsan, Korea (unpublished). 25pp. [Paper available from the Office of this Journal].
- Laake *et al.* 1997. Probability of detecting harbour porpoise from aerial surveys: Estimating  $g(0)$  *Journal of Wildlife Management* 61(1): 63-75.
- Matsuoka, K., Hakamada, T., Kiwada, H., Murase, H. and Nishiwaki, S. 2011. Abundance estimates and trends for humpback whales (*Megaptera novaeangliae*) in Antarctic Areas IV and V based on JARPA sightings data. *J. Cetacean Res. Manage. (special issue 3)*: 75-94.
- Noad, M.J., Dunlop, R.A., Paton, D. and Kniest, H. 2011. Abundance estimates of the east Australian humpback whale population: 2010 survey and update. Paper SC/63/SH22 presented to the IWC Scientific Committee, June 2011, Tromsø, Norway (unpublished). 12pp. [Paper available from the Office of this Journal].
- Olavarria, C., Anderson, M., Paton, D.A., Burns, D., Brasseur, M., Garrigue, C., Hauser, N., Poole, M., Caballero, S., Flórez-Gonzalez, L. and Baker, C.S. 2006. Eastern Australian humpback whale genetic diversity and their relationship with Breeding Stocks D, E, F and G. Paper SC/58/SH25 presented to the IWC Scientific Committee, May 2006, St Kitts and Nevis, West Indies (unpublished). 6pp. [Paper available from the Office of this Journal].
- Olavarria, C., Baker, C.S., Garrigue, C., Poole, M., Hauser, N., Caballero, S., Flórez-González, L., Brasseur, M., Bannister, J., Capella, J., Clapham, P., Dodemont, R., Donoghue, M., Jenner, C., Jenner, M.N., Moro, D., Oremus, M., Paton, D. and Russell, K. 2007. Population structure of South Pacific humpback whales and the origin of the eastern Polynesian breeding grounds. *Mar. Ecol. Prog. Ser.* 330: 257-68.
- Pastene, L.A., Goto, M., Kanda, N., Kitakado, T. and Palsbøll, P.J. 2011. Preliminary mitochondrial DNA analysis of low and high latitude humpback whales of Stocks D, E and F. Paper SC/63/SH9 presented to the IWC Scientific Committee, June 2011, Tromsø, Norway (unpublished). 16pp. [Paper available from the Office of this Journal].

- Paton, D.A., Brookes, L., Burns, D., Franklin, T., Franklin, W., Harrison, P. and Baverstock, P. 2011. Abundance of east coast Australian humpback whales (*Megaptera novaeangliae*) in 2005 estimated using multi-point sampling and capture-recapture analysis. *J. Cetacean Res. Manage. (special issue 3)*: 253-60.
- Rosenbaum, H.C., Pomilla, C., Mendez, M.C., Leslie, M.C., Best, P.B., Findlay, K.P., Minton, G., Ersts, P.J., Collins, T., Engel, M.H., Bonatto, S., Kotze, D.P.G.H., Meyer, M., Barendse, J., Thornton, M., Razafindrakoto, Y., Ngouesso, S., Vely, M. and Kiszka, J. 2009. Population structure of humpback whales from their breeding grounds in the South Atlantic and Indian Oceans. *PLoS ONE* 4(10): 11pp. [e7318. doi: 10.1371/journal.pone.0007318].
- Salgado Kent, C., Jenner, C., Jenner, M., Bouchet, P. and Rexstad, E. 2012. Southern Hemisphere Breeding Stock 'D' humpback whale population estimates from North West Cape, Western Australia. *J. Cetacean Res. Manage* 12(1): 29-38.
- Sremba, A., Hancock-Hanser, B., Branch, T.A., LeDuc, R.L. and Baker, C.S. 2012. Circumpolar diversity and geographic differentiation of mtDNA in the critically endangered Antarctic blue whale (*Balaenoptera musculus intermedia*) *PLoS One* 7: 13pp.

## Appendix 1

### AGENDA

1. Introductory items
  - 1.1 Opening remarks
  - 1.2 Election of Chair
  - 1.3 Appointment of rapporteurs
  - 1.4 Adoption of the agenda
  - 1.5 Review of documents
2. Assessment of Southern Hemisphere Humpback Whales
  - 2.1 Assessment of breeding stocks D, E and F
    - 2.1.1 Abundance, trends and catches
    - 2.1.2 Distribution, movement and population structure
    - 2.1.3 Assessment models
    - 2.1.4 Future work
  - 2.2 Review new information on the Arabian Sea humpback population
  - 2.3 Review new information on breeding stocks
    - 2.3.1 Breeding stock A
    - 2.3.2 Breeding stock B
    - 2.3.3 Breeding stock C
    - 2.3.4 Breeding stock D
    - 2.3.5 Breeding stock G
    - 2.3.6 Feeding grounds
  - 2.4 Antarctic Humpback Whale Catalog
3. Assessment of Southern Hemisphere blue whales
  - 3.1 Review new information
    - 3.1.1 Photo-identification catalogues
    - 3.1.2 Antarctic blue whales
      - 3.1.2.1 Methodological development
      - 3.1.2.2 Planning of future research
    - 3.1.3 Pygmy blue whales
    - 3.1.4 Chilean blue whales
4. Review new information on other species
5. Work plan and budget considerations
  - 5.1 Humpback whales
  - 5.2 Blue whales
6. Adoption of the Report

## Appendix 2

### DESCRIPTION OF A MOVEMENT MODEL FOR THE ASSESSMENT OF BREEDING STOCKS D, E AND F

Andrea Muller and Doug Butterworth

The proposed model for assessment is a basic three stock model (D, E1 and Oceania) that allows for interchange on both the breeding and the feeding grounds. The model diagram and an example of population dynamics equations are given below.

There are numerous assumptions that can be made about the manner in which movement between the stocks occurs. Extensive discussions around this topic took place for the assessment of breeding stocks C1 and C3 in 2008 and 2009 (see SC/64/SH27). Of the models proposed for BSC, the migrant model was considered most suitable for BSD, E1 and Oceania and will therefore be used as the base case model for assessment of these stocks. However for the purposes of illustration

here, the population dynamics for the sabbatical model have been shown, which was the simplest movement model proposed for the BSC assessment.

The sabbatical model assumes that each year a proportion of whales from stock  $i$  moves to stock  $j$  and *vice versa* (for this assessment  $\{i,j\}=\{D,E1\}$  or  $\{E1,O\}$ ). The sabbatical model further assumes that the following year the whales return to their original breeding stocks, where they once again have an equal probability of moving to another stock.<sup>1</sup>

The population numbers are defined in two ways:  $N_y^i$  is the population size of breeding stock  $i$  in year  $y$  and  $\eta_y^i$  is the observed population size once movement has taken place. The dynamics are given as follows:

#### Breeding populations

$$N_{y+1}^i = N_y^i + r^i N_y^i \left( 1 - \left( \frac{N_y^i}{K^i} \right)^\mu \right) - C_y^i \quad i \in \{D, E1, O\} \quad (1)$$

where  $N_y^i$  is the number of whales in the breeding population  $i$  at the start of year  $y$ ,  
 $r^i$  is the intrinsic growth rate (the maximum per capita the population can achieve when its size is very low) of breeding population  $i$ ,  
 $K^i$  is the carrying capacity or pristine population level of breeding population  $i$ ,  
 $\mu$  is the ‘degree of compensation’ parameter; this is set at 2.39, which fixes the level at which MSY is achieved at  $MSYL = 0.6K$ , as conventionally assumed by the IWC SC, and  
 $C_y^i$  is the total catch (in terms of breeding population  $i$  animals) in year  $y$ .

#### Observed breeding ground populations

$$\eta_y^{B,D} = N_y^D - \alpha_{12} N_y^D + \alpha_{21} N_y^{E1} \quad (2)$$

$$\eta_y^{B,E1} = N_y^{E1} - \alpha_{21} N_y^{E1} + \alpha_{12} N_y^D - \alpha_{23} N_y^{E1} + \alpha_{32} N_y^O \quad (3)$$

$$\eta_y^{B,O} = N_y^O - \alpha_{32} N_y^O + \alpha_{23} N_y^{E1} \quad (4)$$

where  $\eta_y^{B,i}$  is the expected number of whales observable in year  $y$  on the breeding grounds associated with breeding stock  $i$ ,  
 $\alpha_{12}$  is the proportion of D whales that move to the E1 breeding grounds, and conversely  $\alpha_{21}$  is the proportion of E1 whales that move to the D breeding grounds, and  
 $\alpha_{23}$  is the proportion of E1 whales that move to the Oceania breeding grounds, and conversely  $\alpha_{32}$  is the proportion of Oceania whales that move to the E1 breeding grounds.

#### Observed feeding ground populations

$$\eta_y^{F,D} = N_y^D - \beta_{12} N_y^D + \beta_{21} N_y^{E1} \quad (5)$$

$$\eta_y^{F,E1,W} = \gamma N_y^{E1} + \beta_{12} N_y^D \quad (6)$$

$$\eta_y^{F,E1,E} = (1 - \beta_{21} - \beta_{23} - \gamma) N_y^{E1} + \beta_{32} N_y^D \quad (7)$$

$$\eta_y^{F,O} = N_y^O - \beta_{32} N_y^O + \beta_{23} N_y^{E1} \quad (8)$$

where  $\eta_y^{F,i}$  is the expected number of whales observable in year  $y$  on the feeding grounds associated with breeding stock  $i$  (note that for E1 there is an eastern and western feeding ground<sup>2</sup>),

<sup>1</sup>The migrant model is identical to the sabbatical model, except that it is assumed that once a whale moves from one population to another, it will remain with the new population behaving exactly as the other whales of that stock.

- $\beta_{12}$  is the proportion of D whales that move to the E1 breeding grounds, and conversely  $\beta_{21}$  is the proportion of E1 whales that move to the D breeding grounds,
- $\beta_{23}$  is the proportion of E1 whales that move to the Oceania breeding grounds, and conversely  $\beta_{32}$  is the proportion of Oceania whales that move to the E1 breeding grounds,
- $\gamma$  is the proportion of E1 whales that go to the western E1 feeding ground, and
- $\gamma^*$  is given by  $(1 - \beta_{21} - \beta_{23} - \gamma)$

#### Catch allocations

The respective breeding and feeding ground catches are allocated to the individual breeding stocks in proportion to the numbers that are present on the breeding/ feeding ground. For example, if  $C_y^{B,i}$  are the catches taken in the breeding ground associated with stock  $i$ , and  $C_y^{F,i}$  are the catches taken in the feeding ground associated with stock  $i$ , then the total BSD catches taken north of 40°S are given by

$$C_y^{N,D} = C_y^{B,D} \left[ (1 - \alpha_{12}) N_y^D / \eta_y^{B,D} \right] + C_y^{B,E1} \left[ \alpha_{12} N_y^D / \eta_y^{B,E1} \right] \quad (9)$$

while the total BSD catches taken south of 40°S are given by

$$C_y^{S,D} = C_y^{F,D} \left[ (1 - \beta_{12}) N_y^D / \eta_y^{F,D} \right] + C_y^{F,E1,W} \left[ \beta_{12} N_y^D / \eta_y^{F,E1,W} \right] \quad (10)$$

### Appendix 3

#### POPULATION MODELING OF EAST AUSTRALIA-OCEANIA SUB-STOCKS

Jennifer Jackson

Sub-stocks BSE1, BSE2, BSE3 and BSF2 show significant genetic differentiation (Olavarria *et al.* 2006; Olavarria *et al.* 2007) yet share common high latitude feeding grounds between 110E-100W. To explore the population history of this region I propose to explore variants on a two-stock Bayesian population model for E1 and Oceania overall (E2, E3, F2) as well as developing two two-stock models within Oceania for E1 and E2, and E3 and F2 respectively. This is a standard density dependent logistic model framework with dynamic allocation of catches (derived from the annual ratio of abundance from the two breeding stocks associated with that feeding ground). Abundance estimates from the region are as laid out in SC/64/[Appendix with dataset suitability tables]. Trend data are available for E1 and E2 (Garrigue *et al.* 2012; Noad *et al.* 2011) while none are available for E3 and F2.

The rationale for the catch allocations shown in Figure 1 is given below:

East Australia (E1) and New Caledonia (E2) are genetically differentiated both through FST and  $\Phi$ ST metrics (Olavarria *et al.* 2006) yet both share a common feeding ground across 130-180°E as revealed by photo ID and microsatellite genotype matching (Constantine *et al.* 2011; Garrigue *et al.* 2010; Rock *et al.* 2006; Steel *et al.* 2011). E1 whales also may feed to the west of this area (110-130°E) according to Discovery marks (Chittleborough 1965) and satellite telemetry data (Gales *et al.* 2009), while E2 whales may feed to the east (180-120°W) according to microsatellite genotypes (Steel *et al.* 2008). Therefore feeding grounds for each are slightly staggered by longitude but contain an area of overlap.

Tonga (E3) and French Polynesia (F2) are also genetically differentiated through FST and  $\Phi$ ST metrics (Olavarria *et al.* 2007) yet share a common feeding ground to the south. As with East Australia and New Caledonia above these appear to be staggered in terms of their connectivity. E3 is more strongly allocated to 120-180°W than F2 (Pastene *et al.* 2011). While both regions have interchanges documented with the Antarctic Peninsula to the far east (Robbins *et al.* 2011; South Pacific Whale Research Consortium 2009), F2 is geographically closer than E3 so might be expected to have stronger connectivity than the latter.

<sup>2</sup>In order to avoid the scenario when all three stocks mix in a single feeding area, an artificial boundary is imposed that splits the E1 feeding ground into an eastern and western section. The model will not allow D whales to migrate to the eastern part of the E1 feeding ground and similarly will not allow Oceania whales to migrate to the western side of the E1 feeding ground. This boundary is set at 130°E.

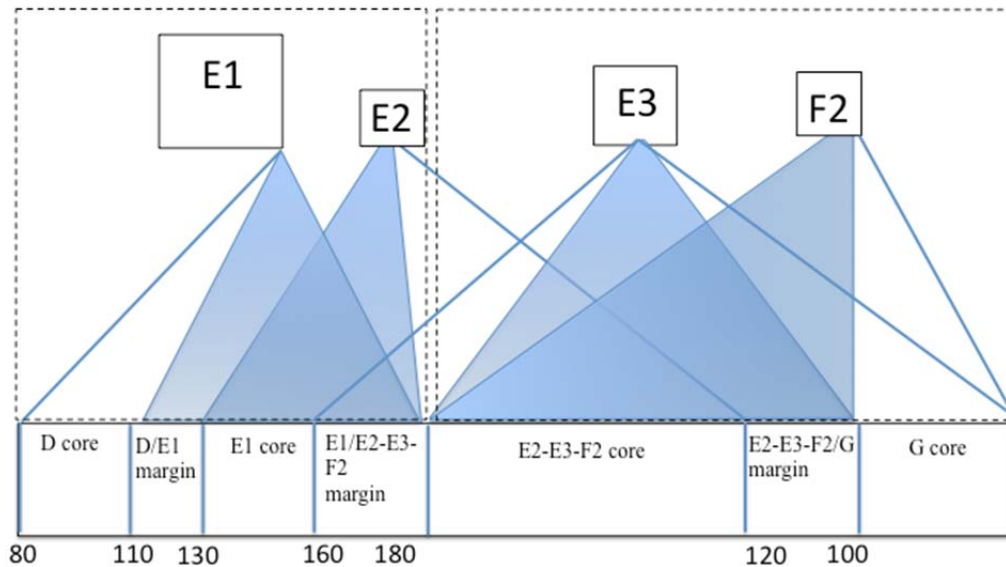

Fig.1. Catch allocation base case (shaded triangles) and sensitivity explorations (clear triangles) for multi-stock Oceania population modeling. For example E2 base case is catches from 130°E-180°, sensitivity case is 130°E-120°W.

## REFERENCES

- Chittleborough RG (1965) Dynamics of two populations of the humpback whale, *Megaptera Novaeangliae* (Borowski). *Australian Journal of Marine and freshwater research* **16**, 33-128.
- Constantine R, Allen J, Beeman P, *et al.* (2011) Comprehensive photo-identification matching of Antarctic Area V humpback whales. In: *Paper SC/63/SH16 presented to the IWC Scientific Committee, June 2011 (unpublished)*. 11pp. [Available from the office of this Journal].
- Gales N, Double MC, Robinson S, *et al.* (2009) Satellite tracking of southbound East Australian humpback whales (*Megaptera novaeangliae*): challenging the feast or famine model for migrating whales. In: *Paper SC/61/SH17 presented to the IWC Scientific Committee, May 2009 (unpublished)*. 12pp. [Available from the office of this Journal].
- Garrigue C, Albertson R, Jackson JA (2012) An anomalous increase in the New Caledonia humpback whales breeding sub-stock E2. In: *Paper SC/64/SH6 presented to the IWC Scientific Committee, June 2012 (unpublished)*. 25pp. [Available from the office of this Journal].
- Garrigue C, Peltier H, Ridoux V, Franklin T, Charrassin JB (2010) CETA: a new cetacean observation program in East Antarctica. In: *Paper SC/62/SH3 presented to the IWC Scientific Committee, June 2010 (unpublished)*. 5pp. [Available from the office of this Journal].
- Noad M, Dunlop RA, Paton D, Kniest H (2011) Abundance estimates of the east Australian humpback whale population: 2010 survey and update. In: *Paper SC/63/SH22 presented to the IWC Scientific Committee, May 2011 (unpublished)*. 12pp. [Available from the office of this Journal].
- Olavarria C, Aguayo A, Acevedo J, *et al.* (2006) Genetic differentiation between two feeding areas of the Eastern South Pacific humpback whale population: Update on SC/57/SH3. In: *Paper SC/A06/HW29 submitted to the IWC southern hemisphere humpback workshop, Hobart, April 2006*. 7pp.
- Olavarria C, Baker CS, Garrigue C, *et al.* (2007) Population Structure of South Pacific humpback whales and the origin of the eastern Polynesian breeding grounds. *Marine Ecology Progress Series* **330**, 257-268.
- Pastene L, Goto M, Kanda N, Kitakado T, Palsboll PJ (2011) Preliminary mitochondrial DNA analysis of low and high latitude humpback whales of Stocks D, E and F. In: *Paper SC/63/SH9 presented to the IWC Scientific Committee, June 2011 (unpublished)*. 16pp. [Available from the office of this Journal].
- Robbins J, Dalla Rosa L, Allen JM, *et al.* (2011) Return movement of a humpback whale between the Antarctic Peninsula and American Samoa: a seasonal migration record. *Endangered Species Research* **13**, 117-121.
- Rock J, Pastene LA, Kaufman G, *et al.* (2006) A note on East Australia Group V Stock humpback whale movement between feeding and breeding areas based on photo-identification. *Journal of Cetacean Research and Management* **8**, 301-305.
- South Pacific Whale Research Consortium (2009) Report of the Annual Meeting of the South Pacific Whale Research Consortium. In: *Paper SC/61/SH15 presented to the IWC Scientific Committee, May 2009 (unpublished)*. 15pp. [Available from the office of this Journal].
- Steel D, Garrigue C, Poole M, *et al.* (2008) Migratory connections between humpback whales from South Pacific breeding grounds and Antarctic feeding areas based on genotype matching. In: *Paper SC/60/SH13 presented to the IWC Scientific Committee, May 2008 (unpublished)*. 9pp. [Available from the office of this Journal].
- Steel D, Schmitt N, Anderson M, *et al.* (2011) Initial genotype matching of humpback whales from the 2010 Australia/New Zealand Antarctic Whale Expedition (Area V) to Australia and the South Pacific. In: *Paper SC/61/SH10 presented to the IWC Scientific Committee, June 2011 (unpublished)*. 8pp. [Available from the office of this Journal].

## Appendix 4

### SHORT TITLE

Modeling of Southern Hemisphere Humpback whale populations

### RELEVANT AGENDA ITEM (NO. AND TITLE)

2.3.4 PREPARATION FOR ASSESSMENT (BSD, E, AND F)

### BRIEF DESCRIPTION OF PROJECT

The project will focus on a combined assessment of humpback breeding stocks D, E and Oceania using the model proposed at IWC/64. Methods used will be based upon the Bayesian methodology as developed and presented for BS C and BS B comprehensive assessments recently completed. Initial results will utilize the data agreed at IWC 64, and results will be presented at the 2013 SC meeting. Further model developments and refinements in association with the final set of agreed data (and their sensitivities) would be presented at 2013 SC meeting should the Scientific Committee decide to so request.

### TIMETABLE

Report on initial results at 2013 SC meeting, with final results at 2014 SC meeting.

### RESEARCHERS' NAMES

Butterworth, Johnston, Muller

### ESTIMATED COST WITH BREAKDOWN AS NEEDED

Salary contribution for period up to and including 2012 SC meeting: **£3,000**

## Appendix 5

### SHORT TITLE

Antarctic Humpback Whale Catalogue

### RELEVANT AGENDA ITEM (NO. AND TITLE)

2.1 Assessment of Southern Hemisphere Humpback Whales.

### BRIEF DESCRIPTION OF PROJECT AND WHY IT IS NECESSARY TO YOUR SUB-COMMITTEE

The Antarctic Humpback Whale Catalogue collates photo-identification information from Southern Hemisphere humpback whales. We have made tremendous progress in the catalogue with funding support from the IWC. Increasing awareness of the project among research organizations, tour operators and other potential contributors has widened the scope of the collection; research efforts in areas that had not previously been sampled have extended the geographic coverage. The AHWC has grown by 25% in the last two years, adding 1,127 new individuals, and increasing the time required to analyse photographs. With decreased funding during this contract period however, the number of individuals catalogued declined somewhat from the previous year. There continues to be strong interest in the catalogue, and photographs catalogued during the contract period included substantial additions from areas that were previously under-represented in the collection. The project has a hemispheric scope and the database spans more than two decades. As a result the AHWC is in an excellent position to make a substantial contribution to the Southern Ocean Research Partnership and other research and management initiatives.

Recognizing the scope of work to be accomplished in the coming year and the importance of timely analysis to the contributing researchers and the scientific community, and reflecting recent changes in the international currency markets, we are requesting that funding be granted at £15,000 GBP. We will seek funding from other sources to provide the remaining funds required. Additional resources are provided by College of the Atlantic, including equipment and student assistants provided by College of the Atlantic, and time donated by.

### TIMETABLE

1 year

### RESEARCHERS' NAMES

Project Investigators Judith Allen and Carole Carlson.



**ESTIMATED TOTAL COST WITH BREAKDOWN AS NEEDED (E.G. SALARY, EQUIPMENT)**

Salary: Project and database management	3,200
Photo comparison	10,000
Fringe @ 16.5%	1,650
Supplies	150
Total Budget	£15,000

**Appendix 6**

**SHORT TITLE**

Photo matching of Antarctic blue whales

**RELEVANT AGENDA ITEM (NO. AND TITLE)**

3.1 Assessment of Southern Hemisphere Blue Whales.

**BRIEF DESCRIPTION OF PROJECT AND WHY IT IS NECESSARY TO YOUR SUB-COMMITTEE**

The goal of this project is to compare the existing SOWER Antarctic blue whale catalogue (about 160 individuals) and the existing photo-id material collected from JARPA which are already digitized. This project may add new individuals to the Antarctic blue whale catalogue and provide new data on the movements of Antarctic blue whales both within and between years. The subcommittee has requested for several years that this work be undertaken.

**TIMETABLE**

1 year

**RESEARCHERS' NAME**

Paula Olson, Southwest Fisheries Science Center, La Jolla, California

**ESTIMATED TOTAL COST WITH BREAKDOWN AS NEEDED (E.G. SALARY, EQUIPMENT)**

A total budget of £3,000 is requested. This includes salary for an estimated 150 hours of work.

**Appendix 7**

**SHORT TITLE**

Southern Hemisphere Blue Whale Catalogue 2012/2013

**RELEVANT AGENDA ITEM (NO. AND TITLE)**

Item 3. Assessment of Southern Hemisphere Blue Whales

**BRIEF DESCRIPTION OF PROJECT AND WHY IT IS NECESSARY TO YOUR SUB-COMMITTEE**

The Southern Hemisphere Blue Whale Catalogue (SHBWC) is an international collaborative effort to facilitate cross-regional comparison of blue whale photo-identifications catalogues. In 2006 the Scientific Committee of the International Whaling Commission (IWC) agreed to initiate an in-depth assessment of Southern Hemisphere blue whales (IWC, 2006) and in 2008, the Committee endorsed a proposal to establish a central web-based catalogue of blue whale identification photographs, known as the Southern Hemisphere Blue Whale Catalogue (SHBWC) (IWC, 2008).

Currently the SHBWC holds photo-identification catalogues of researchers from major areas off Antarctica, Australia, Eastern South Pacific and the Eastern Tropical Pacific (IWC, 2011). Comparisons among catalogues off Chile found one match over ten years (Galletti Vernazzani and Cabrera, 2011). Preliminary results of 2011-2012 catalogue comparisons between the eastern South Pacific Ocean, Eastern Tropical Pacific Ocean (ETP) and Southern Ocean found no matches (Galletti Vernazzani and Olson, 2012).

During 2012-2013 it is expected that comparisons between Australian catalogues, and between ETP, Southeast Pacific and Antarctica are finalized. Once comparisons among Australian catalogues, inter-regional matching will be undertaken with the rest of the areas but it is likely this will occur in 2013/2014 and therefore no budgetary consideration for matching are included in this period. Results of comparisons among different regions in Southern Hemisphere will improve the understanding of basic questions relating to blue whale populations in the southern hemisphere such as defining population boundaries, migratory routes and model abundance estimates.

**TIMETABLE**

<b>Dates</b>	<b>Task</b>
2012/2013	Software improvements and maintenance
2012/2013	Regional comparisons among catalogues from Australia/ New Zealand/ Indonesia regions
2012/2013	Finalize comparisons among catalogues from ETP, Southern Ocean and eastern South Pacific
June 2013	Final report to IWC

**RESEARCHERS' NAMES**

Bárbara Galletti (Catalogue curator, regional coordinator and contributor)

Paula Olson (Regional coordinator and contributor)

Chandra Salgado (Regional coordinator)

Contributors: Chris Burton, Asha de Vos, Paul Ensor, Tim Gerrodette, Peter Gill, Curt Jenner, Luciana Moller, Margie Morrice, Daniel Palacios

**ESTIMATED TOTAL COST WITH BREAKDOWN AS NEEDED (E.G. SALARY, EQUIPMENT)**

**Personnel**

Photo comparisons (2012-2013)<sup>31</sup> £ 0

Project and database management £2.000

**Supplies and web hosting** £1.000

**Total** £ 3.000

**REFERENCES**

Galletti Vernazzani, B. and Cabrera, E. 2011. Long term mark-recapture of blue whales in Chilean Waters. Paper SC/63/SH8 presented to the IWC Scientific Committee, June 2011 (unpublished). 10pp. [Available from the authors]

Galletti Vernazzani, B. and Olson, P. 2012. Progress of between region comparison under Southern Hemisphere Blue Whale Catalogue (SHBWC). Paper SC/64/SH20 presented to the IWC Scientific Committee, June 2012 (unpublished). 4pp. [Available from the authors]

International Whaling Commission. 2006. Report of the Scientific Committee. Annex H. Other Southern Hemisphere Whale Stocks. *J. Cetacean Res. Manage.*

International Whaling Commission. 2008. Report of the Scientific Committee. Annex H. Other Southern Hemisphere Whale Stocks. *J. Cetacean Res. Manage.*

International Whaling Commission. 2011. Report of the Scientific Committee. Annex H. Other Southern Hemisphere Whale Stocks. *J. Cetacean Res. Manage.*

<sup>31</sup>Regional comparisons among Australia catalogues as well as inter-regional comparisons among eastern South Pacific, ETP and Southern Ocean needs to be finalized and funds to conduct this work was already granted in 2011.